



SHAPES

by

DUNE

SHAPES
by
DUNE

SHAPES

CONCEPT

La colección SHAPES de DUNE surge para ahondar en la exploración de los contornos y los volúmenes. Inspirada en la moda, la edificación y la propia naturaleza. SHAPES se sumerge en el estudio de las líneas, tanto rectas como orgánicas, para desarrollar un producto con la geometría como protagonista.

La versatilidad de las piezas de esta colección, al disponerlas en diferentes posiciones o combinarlas entre sí, otorga un sinfín de posibilidades. Las paredes se convierten en lienzos en blanco donde arquitectos e interioristas pueden crear sus combinaciones jugando con las formas y los relieves.

Las composiciones proporcionales ó asimétricas que resultan de la distribución de las piezas, aportan distinción y un marcado carácter estético a los proyectos.

Un mundo de oportunidades para la creación de espacios exclusivos y únicos.

The SHAPES collection by DUNE arises to deepen the exploration of outlines and volumes. Inspired by fashion, building and nature itself. SHAPES is immersed in the study of lines, both straight and organic, to develop a product with geometry as the protagonist.

The versatility of the pieces of this collection, when placed in different positions or combined with each other, provides endless possibilities.

The walls become blank canvases where architects and interior designers can create their own combinations by playing with shapes and reliefs.

Proportional or asymmetric compositions resulting from the distribution of pieces, bring a distinctive and strong aesthetic character to the projects.

A world of opportunities to create exclusive and unique spaces.



INDICE/ INDEX

SHAPES #1

5-34
JAPAN
KIOTO
MULTISHAPES
ORIGAMI

SHAPES #4

71-85
TRANSVERSE 1
TRANSVERSE 2
TRANSVERSE 3
TRANSVERSE 4

SHAPES #2

35-55
ARIA
BIVIO
LUNA
MANDORLA

SHAPES #5

86-98
LONDON
HEXALINE
MAJESTIC DECOR

SHAPES #3

56-70
STRIPES
STRIPES MIX

98
CARACTERÍSTICAS TÉCNICAS / TECHNICAL INFORMATION
OPCIONES DE COLOCACIÓN / INSTALLATION OPTIONS

109
TABLA DE EMBALAJES Y USOS
PACKAGING AND USE LIST

110
SIMBOLOGÍA
SYMBOLS

SHAPES #1

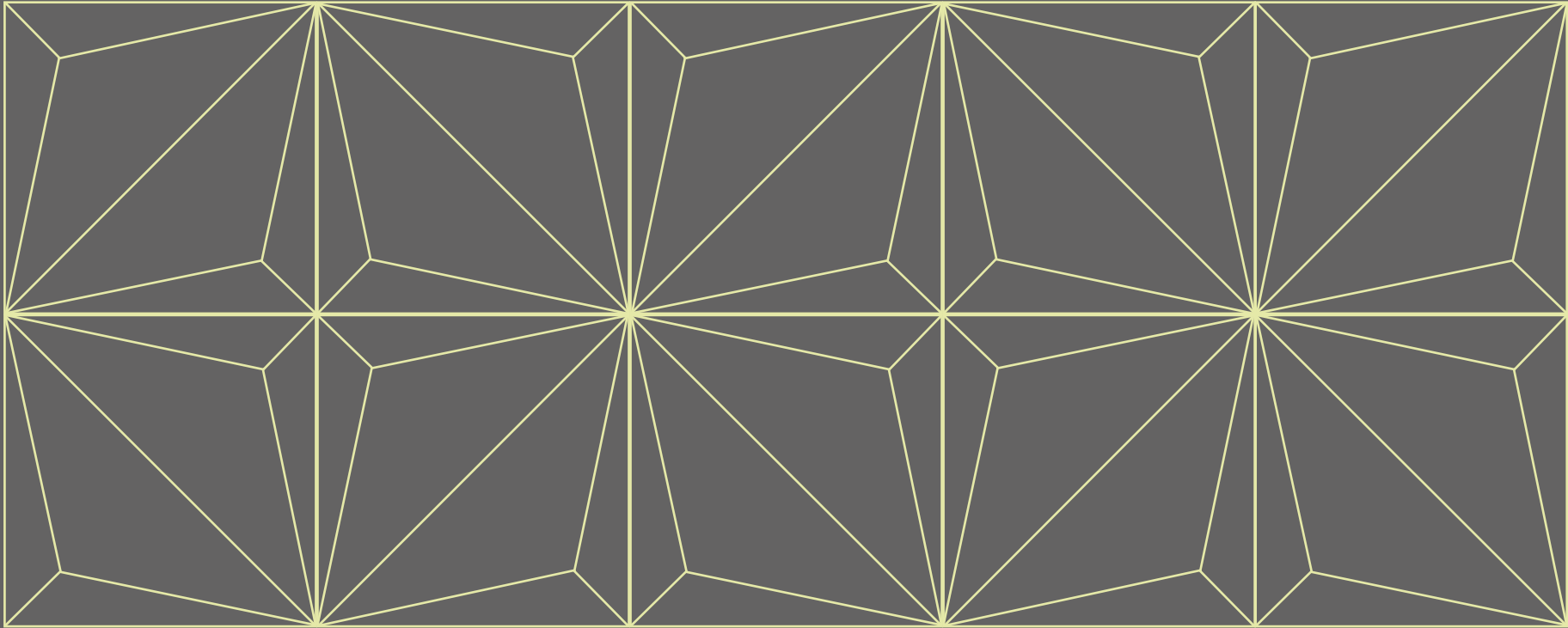

La inspiración surge de las formas del ORIGAMI, antiguo arte japonés que, a base de pliegues, logra que el papel adopte las formas más creativas y variadas, transmitiendo calma y paciencia a quien lo practica. Esta colección consta de tres tonalidades mate: Blanco, Negro y Gris; una brillo: Blanco; y una metalizada: Bronzo.

Cuenta con dos relieves en PVD Oro (Origami y Japan) y dos en PVD Plata (Kioto y Multishapes) que, bien solos o complementando a los acabados Blanco, Negro y Gris, aportan un toque muy sofisticado. A cada uno de los relieves se le ha aplicado un juego de texturas en pasta de vidrio y se ha recubierto con PVD, potenciando el contraste del fondo mate con el brillo de la pasta de vidrio.

The inspiration arises from the forms of ORIGAMI, the ancient japanese art of paper folding, in which paper is folded into the most creative and varied shapes imparting those who practice it with calm and patience. This collection consists of three matt tones: White, Black and Gray; a gloss tone: White; and a metallic one: Bronze.

It also includes two reliefs in PVD Gold (Origami and Japan) and two in PVD Silver (Kyoto and Multishapes) which, either alone or in combination with the White, Black and Grey finishes, provide a very sophisticated touch. A texture in pâte-de-verre is applied to each of the reliefs and they are coated with PVD, highlighting the contrast between the matt background and the pâte- de-verre.

#1

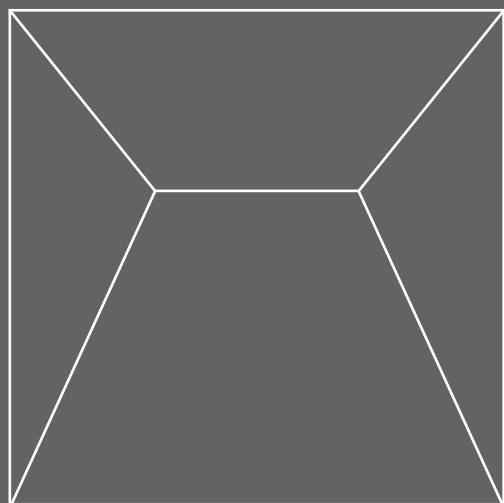

japan

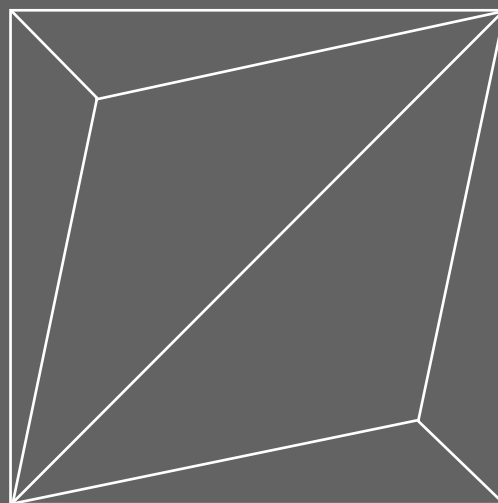

origami

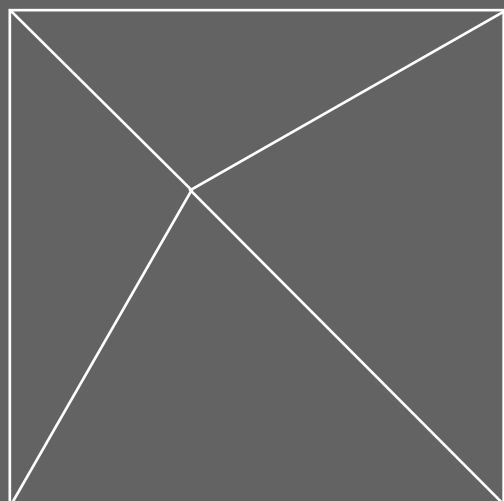

kioto

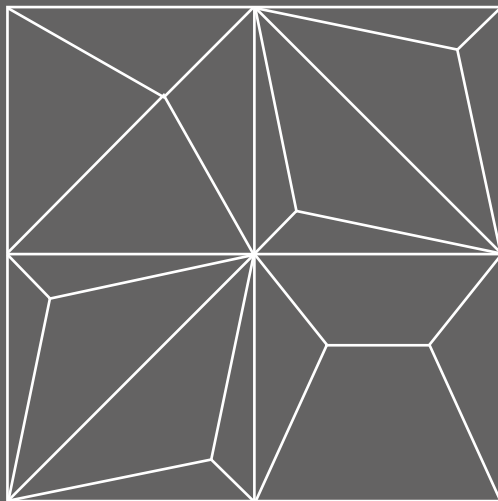

multishapes



white gloss

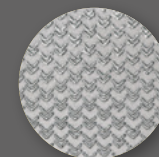

silver



white

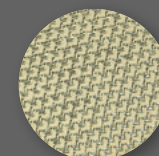

gold



smoke



dorado

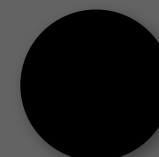

black



bronzo

SHAPES #1

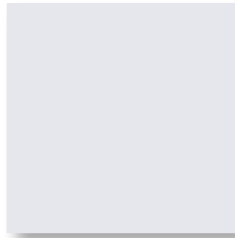

187331 Shapes White Gloss
25x25 cm./9.8"x9.8" M914



187345 Origami White Gloss
25x25 cm./9.8"x9.8" M941

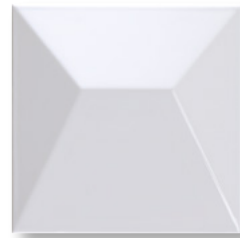

187341 Japan White Gloss
25x25 cm./9.8"x9.8" M941



187337 Kioto White Gloss
25x25 cm./9.8"x9.8" M941



187349 Multishapes White Gloss
25x25 cm./9.8"x9.8" M941

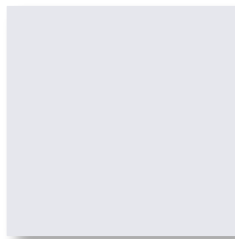

187328 Shapes White
25x25 cm./9.8"x9.8" M914



187342 Origami White
25x25 cm./9.8"x9.8" M941



187338 Japan White
25x25 cm./9.8"x9.8" M941



187334 Kioto White
25x25 cm./9.8"x9.8" M941



187346 Multishapes White
25x25 cm./9.8"x9.8" M941

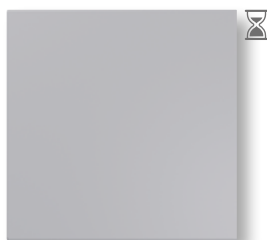

187330 Shapes Smoke
25x25 cm./9.8"x9.8" M914



187344 Origami Smoke
25x25 cm./9.8"x9.8" M941



187340 Japan Smoke
25x25 cm./9.8"x9.8" M941

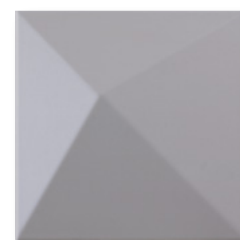

187336 Kioto Smoke
25x25 cm./9.8"x9.8" M941



SHAPES #1

Vo   9 mm



187329 Shapes Black
25x25 cm./9.8"x9.8" M914



187343 Origami Black
25x25 cm./9.8"x9.8" M941

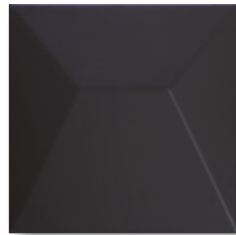

187339 Japan Black
25x25 cm./9.8"x9.8" M941



187335 Kioto Black
25x25 cm./9.8"x9.8" M941



187347 Multishapes Black
25x25 cm./9.8"x9.8" M941



187424 Shapes Bronzo
25x25 cm./9.8"x9.8" M941



187485 Origami Bronzo
25x25 cm./9.8"x9.8" M963



187487 Japan Bronzo
25x25 cm./9.8"x9.8" M963



187486 Kioto Bronzo
25x25 cm./9.8"x9.8" M963



187488 Multishapes Bronzo
25x25 cm./9.8"x9.8" M963



187352 Kioto Silver
25x25 cm./9.8"x9.8" D659

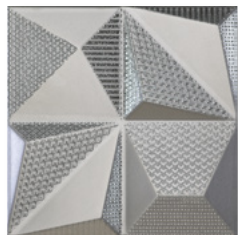

187353 Multishapes Silver
25x25 cm./9.8"x9.8" D659

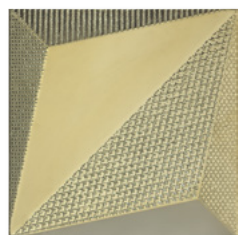

187350 Origami Gold
25x25 cm./9.8"x9.8" D659

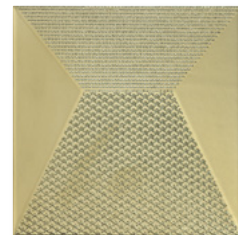

187351 Japan Gold
25x25 cm./9.8"x9.8" D659



188231 Origami Dorado
25x25 cm./9.8"x9.8" M983



188232 Multishapes Dorado
25x25 cm./9.8"x9.8" M983



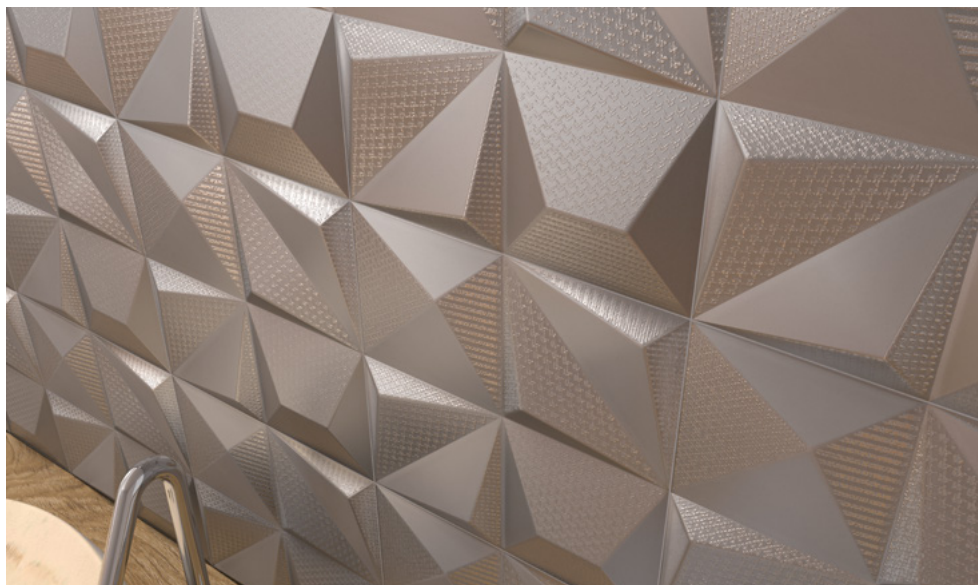

Multishapes. Es una miniatura de los cuatro relieves: dos módulos ORIGAMI, un módulo JAPAN y otro KIOTO. *Multishapes. This is a combination of miniature versions of the 3 main relieves: two ORIGAMI modules, one JAPAN module and one KIOTO module.*

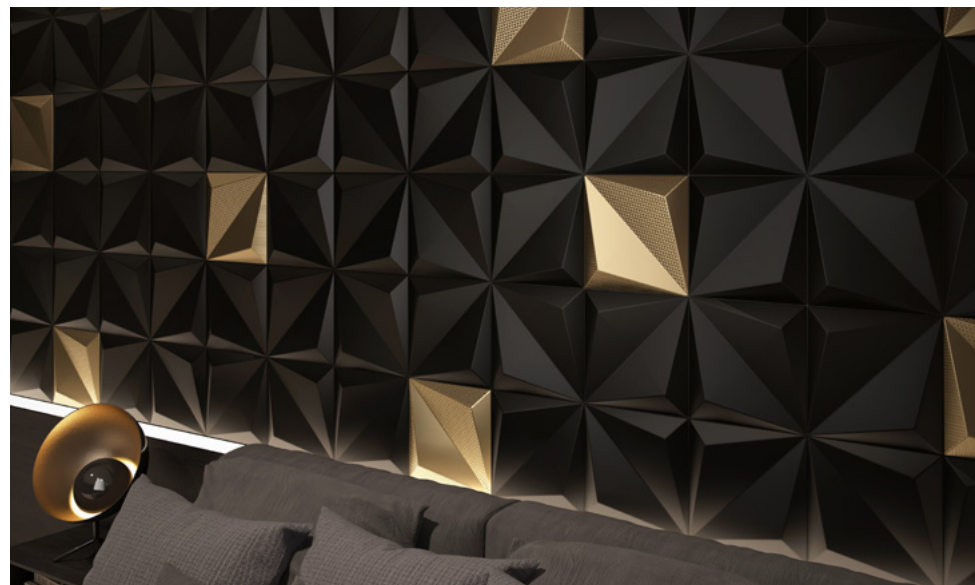

Origami. La simetría de este relieve surcado por una diagonal, emula las formas que adopta el papel cuando se crea con él. *Origami. The symmetry of this relief marked by a diagonal line, emulates the shapes that the paper adopts when folded.*

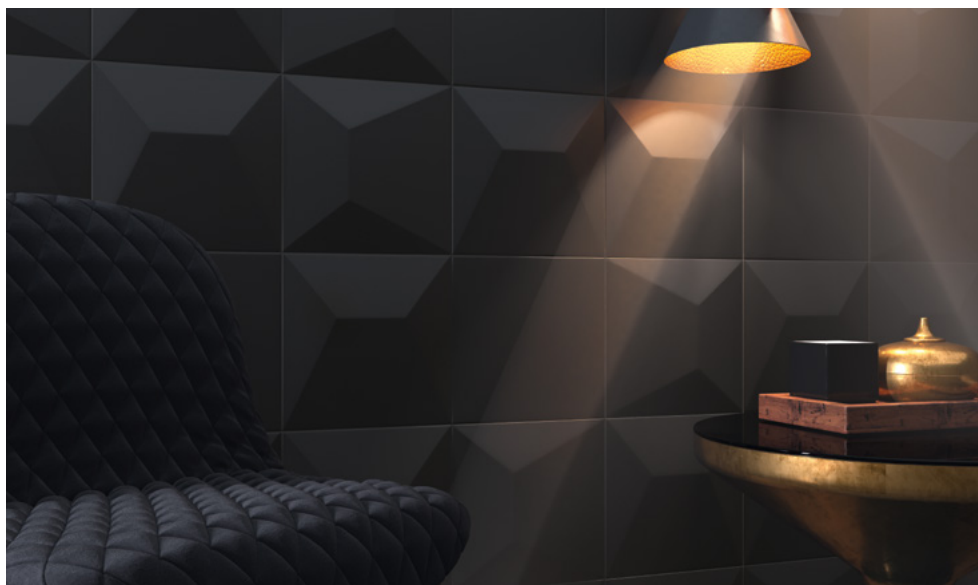

Japan. Este relieve debe su nombre al lugar de inspiración de la colección. Posee una forma piramidal, aunque el vértice de la pirámide ha sido truncado. Su forma nos recuerda a los tejados de los santuarios y templos Japoneses. *Japan. This relief owes its name to the place of inspiration of the collection. It has a pyramidal shape, although the vertex of the pyramid has been truncated. Its shape reminds us of the roofs of Japanese shrines and temples.*



Kioto. La capital cultural de Japón da nombre a este relieve con forma piramidal. Una pirámide cuyo vértice ha sido desplazado. *Kioto. This relief, with pyramidal shape, is named after the cultural capital of Japan. A pyramid whose vertex has been displaced.*



188231 Origami Dorado 25x25 cm
188223 Calacatta Superwhite Rec 60x120 cm



187343 Origami Black 25x25 cm

SHAPES



187346 Multishapes White 25x25 cm
187328 Shapes White 25x25 cm



187340 Japan Smoke 25x25 cm



187345 Origami White Gloss 25x25 cm
187337 Kioto White Gloss 25x25 cm



187346 Multishapes White 25x25 cm
187533 Multishapes Silver 25x25 cm



187338 Japan White 25x25 cm
187328 Shapes White 25x25 cm

SHAPES

188232 Multishapes Dorado 25x25 cm./9.8" x9.8"

SHAPES

EVE
LOVE
FACE
JOY



187334 Kioto White 25x25 cm



187488 Multishapes Bronzo 25x25 cm



187485 Origami Bronzo 25x25 cm

187486 Kioto Bronzo 25x25 cm

SHAPES

187347 Multishapes Black 25x25 cm



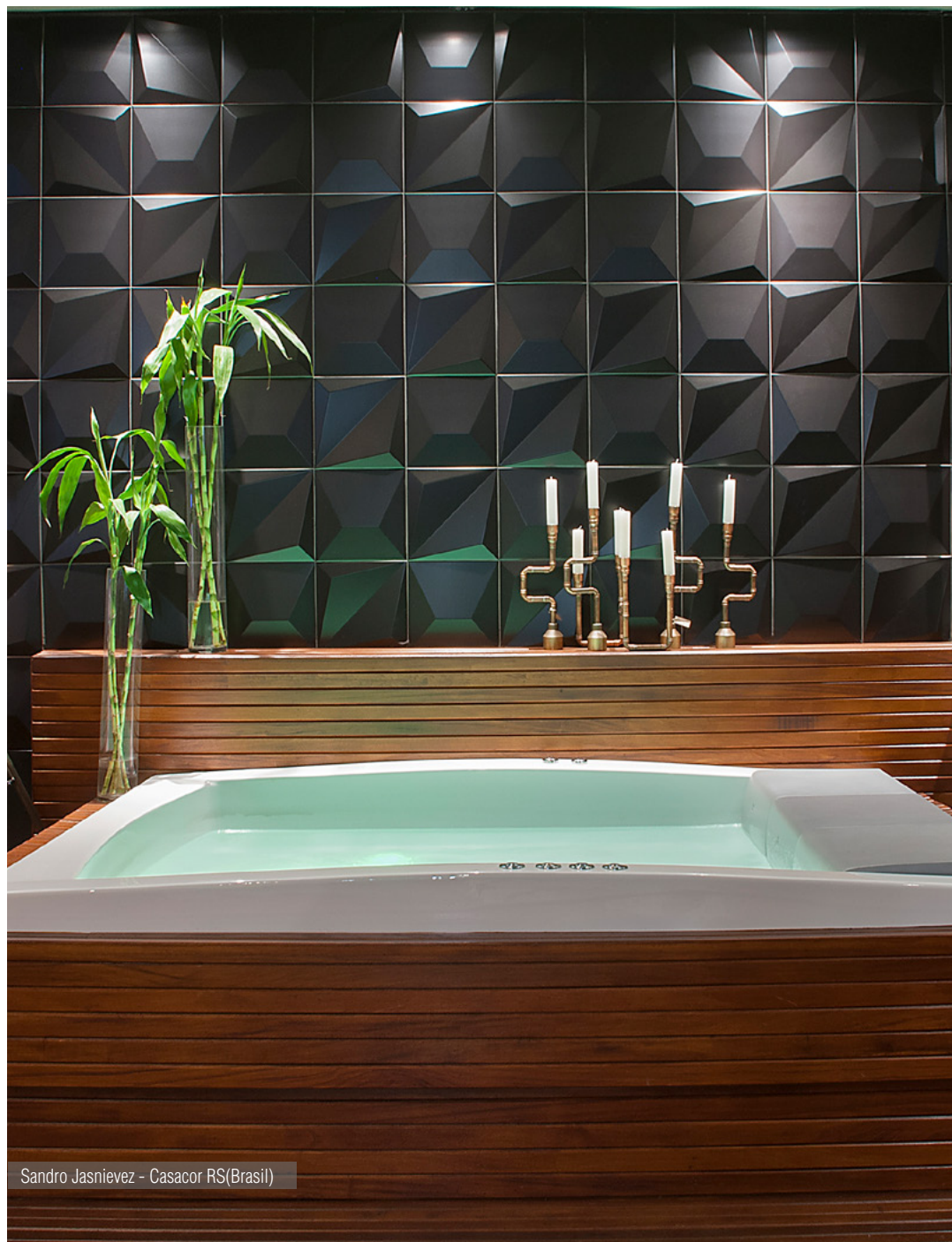

Sandro Jasniewicz - Casacor RS(Brasil)



187339 Japan Black 25x25 cm
187343 Origami Black 25x25 cm



187488 Multishapes Bronzo 25x25 cm

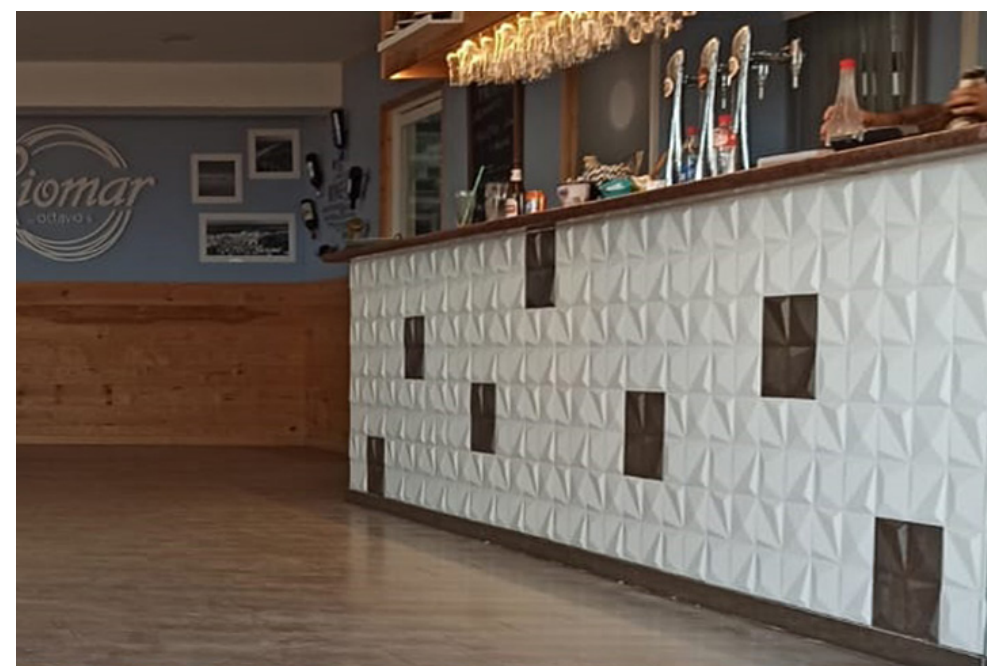

187346 Multishapes White 25x25 cm
187353 Multishapes Silver 25x25 cm

SHAPES



187338 Japan White 25x25 cm
187351 Japan Gold 25x25 cm



187334 Kioto White 25x25 cm

BÁLNEÁRIÓ
CAMBORIÚ



187343 Origami Black 25x25 cm
187339 Japan Black 25x25 cm
187350 Origami Gold 25x25 cm
187351 Japan Gold 25x25 cm



Okura Villas&suites, Guadalajara (Mexico)

187345 Origami White Gloss 25x25 cm



Temptation Cancun Resort, Qroo(Mexico)

187347 Multishapes Black 25x25 cm



187347 Multishapes Black 25x25 cm

SHAPES

187328 Shapes White 25x25 cm
187342 Origami White 25x25 cm
187338 Japan White 25x25 cm
187334 Kioto White 25x25 cm

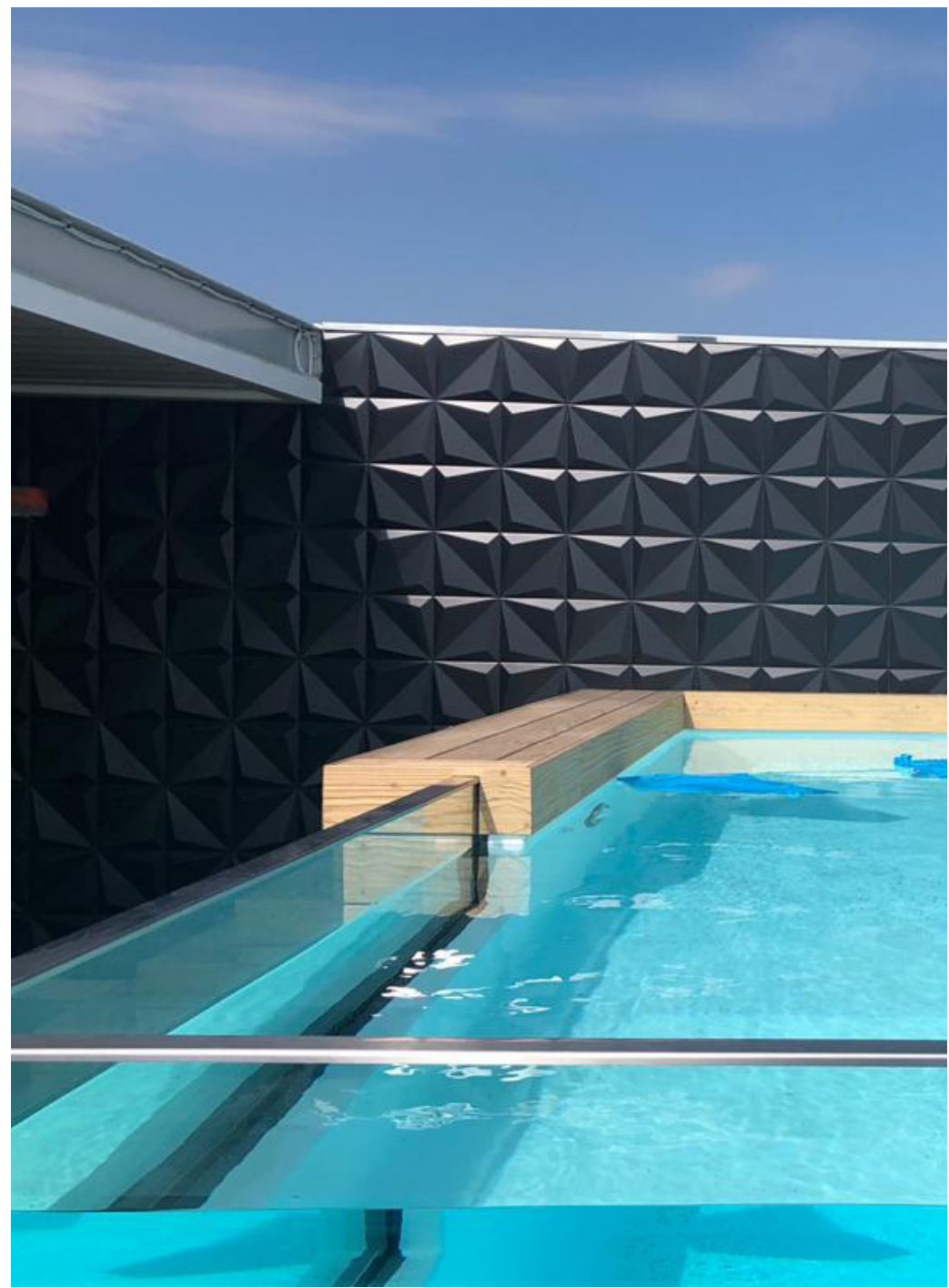

187343 Origami Black 25x25 cm



Temptation Cancun Resort, Qroo(Mexico)

187349 Multishapes White Gloss 25x25 cm



188232 Multishapes Dorado 25x25 cm

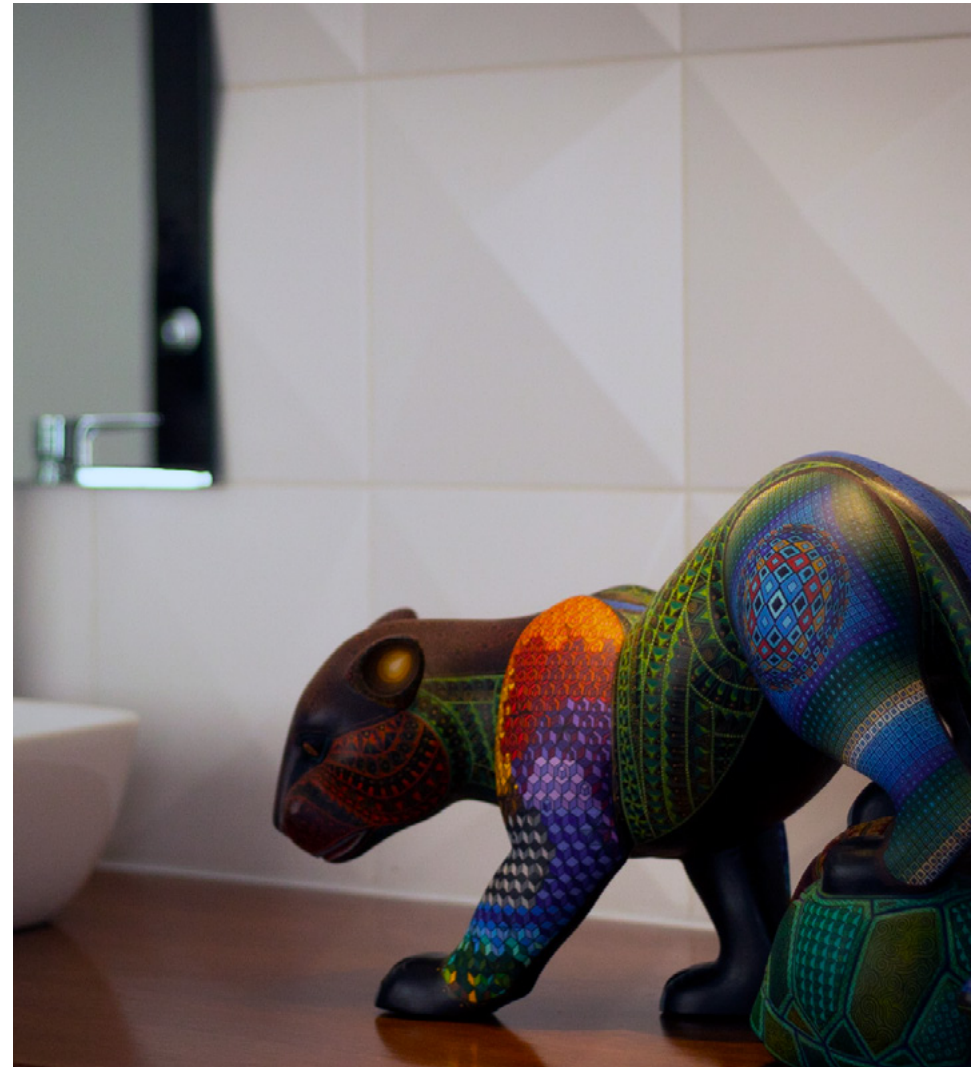

187334 Kioto White 25x25 cm



187343 Origami Black 25x25 cm
187350 Origami Gold 25x25 cm

SHAPES #2

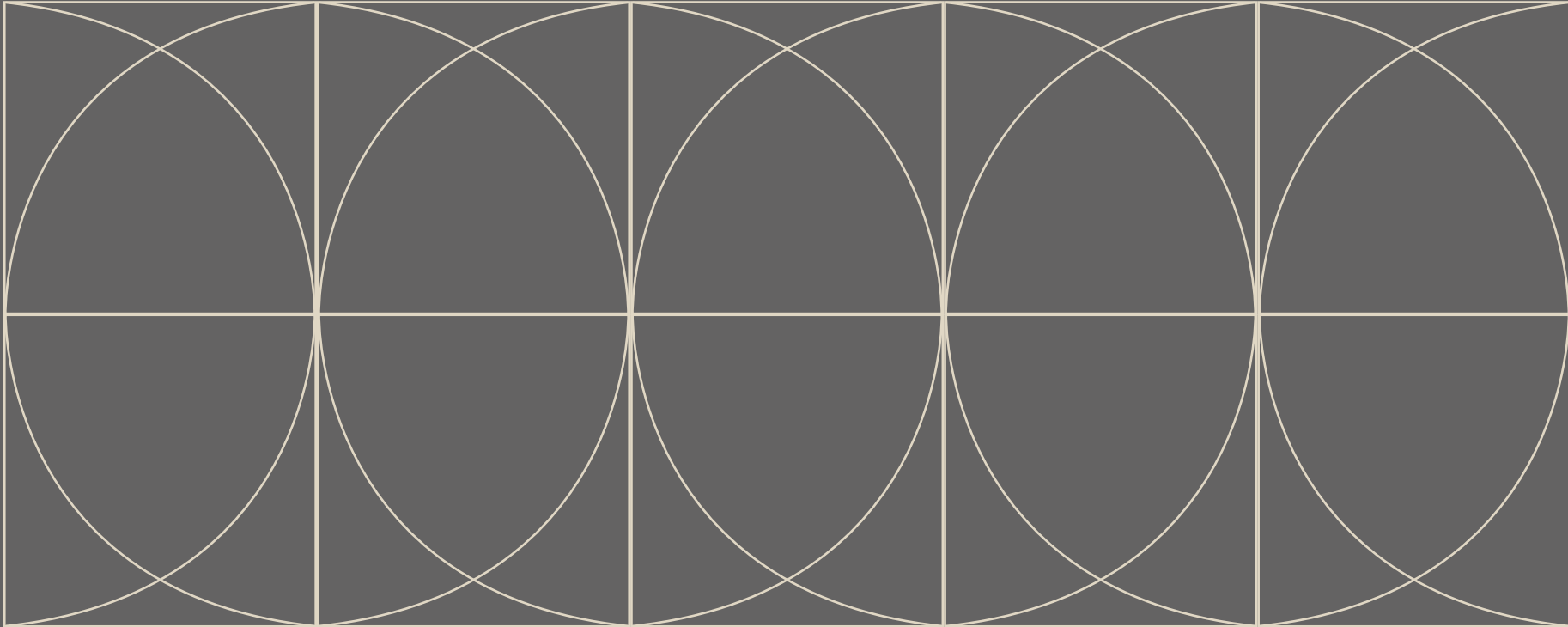

Con la mirada puesta en Asia nos inspiramos en la belleza de las formas orgánicas y curvas. Esta colección es una oda a la naturaleza. Las formas de los relieves, en apariencia simples, dan un sinfín de opciones de colocación. Consta de tres tonalidades mate: Blanco, Panna y Greige; una brillo: Luce; y una metalizada: Bronzo.

Al igual que la anterior esta colección propone dar rienda suelta a la creatividad, para así crear, a partir de la simplicidad, una composición compleja donde las luces y las sombras sean las protagonistas.

With our eyes to Asia, we are inspired by the beauty of organic and curved forms. This collection is an ode to nature. The shapes of the reliefs, seemingly simple, offer an endless possibility of pattern layouts. This collection consists of three matt tones: White, Panna and Greige; a gloss tone: Luce; and a metallic one: Bronzo.

As with the previous one, this collection proposes to give free rein in creativity, in order to create, from the simplicity, a complex composition where lights and shades are the protagonists.

#2

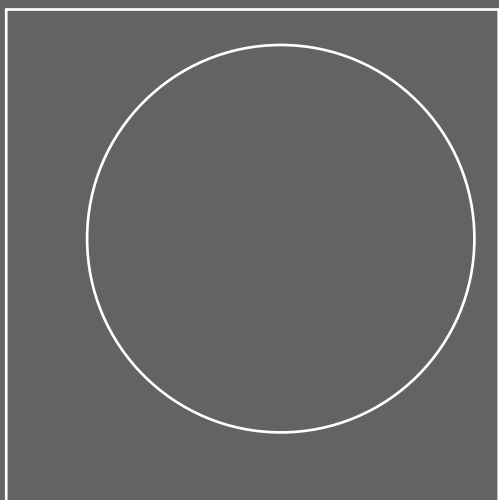

luna

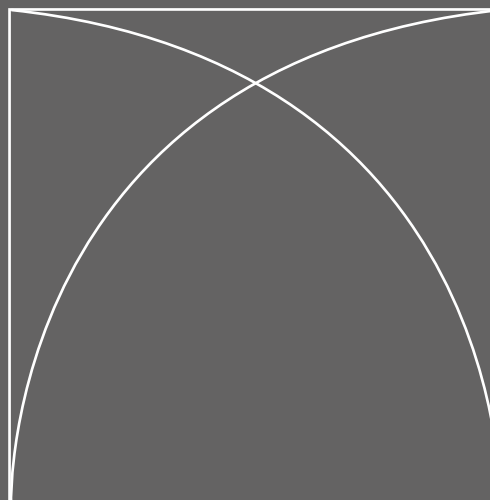

bivio

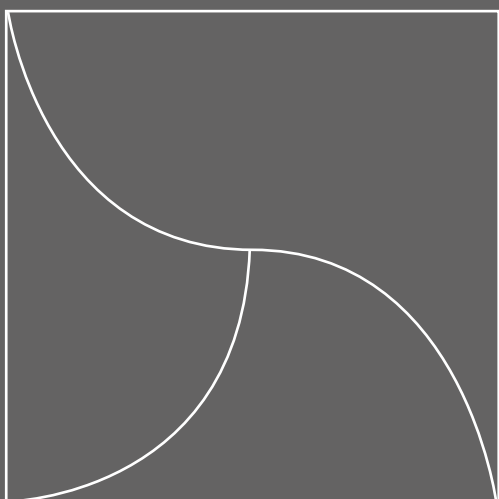

aria

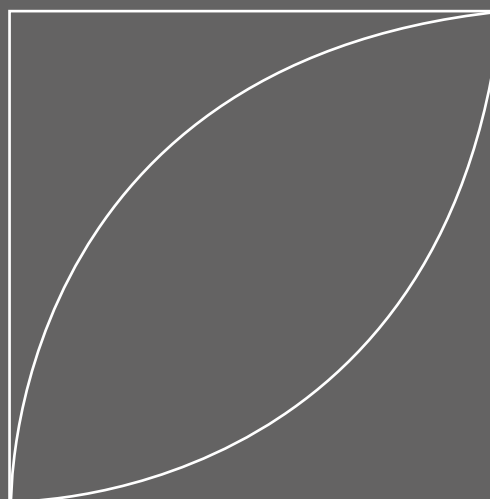

mandorla

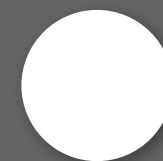

white



luce



panna



greige



bronzo

SHAPES #2

MATT V₀ 9 mm

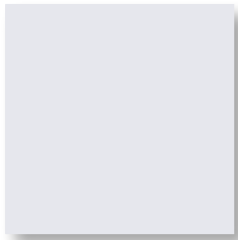

187328 Shapes White
25x25 cm./9.8"x9.8" M914



187406 Bivio White
25x25 cm./9.8"x9.8" M941



187412 Mandorla White
25x25 cm./9.8"x9.8" M941

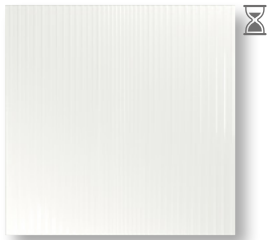

187434 Shapes Luce
25x25 cm./9.8"x9.8" M927



187439 Bivio Luce
25x25 cm./9.8"x9.8" M960



187433 Luna Luce
25x25 cm./9.8"x9.8" M960



187432 Aria Luce
25x25 cm./9.8"x9.8" M960



SHAPES #2

MATT Vo    9 mm

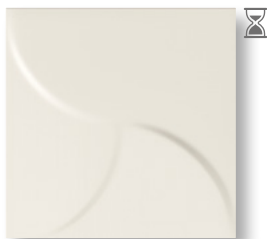

187417 Aria Panna
25x25 cm./9.8"x9.8" M941



187408 Bivio Panna
25x25 cm./9.8"x9.8" M941

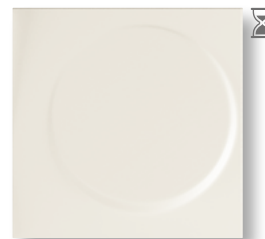

187411 Luna Panna
25x25 cm./9.8"x9.8" M941



187414 Mandorla Panna
25x25 cm./9.8"x9.8" M941

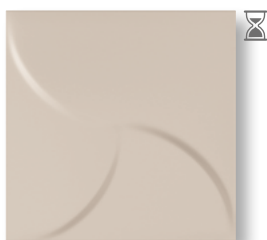

187416 Aria Greige
25x25 cm./9.8"x9.8" M941



187407 Bivio Greige
25x25 cm./9.8"x9.8" M941

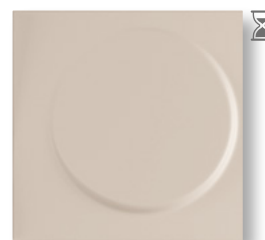

187410 Luna Greige
25x25 cm./9.8"x9.8" M941



187413 Mandorla Greige
25x25 cm./9.8"x9.8" M941



187424 Shapes Bronzo
25x25 cm./9.8"x9.8" M941

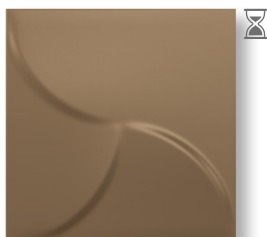

187421 Aria Bronzo
25x25 cm./9.8"x9.8" M963

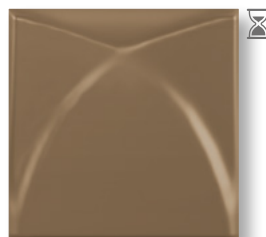

187418 Bivio Bronzo
25x25 cm./9.8"x9.8" M963

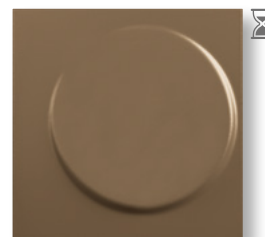

187419 Luna Bronzo
25x25 cm./9.8"x9.8" M963

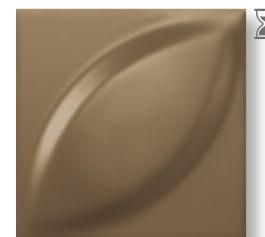

187420 Mandorla Bronzo
25x25 cm./9.8"x9.8" M963





Mandorla. "Almendra" en italiano. Esta forma tiene un gran significado en el mundo del arte. Su forma proviene de dos círculos que se intersectan. Representa el camino entre los dos mundos, el terrenal y el celestial. También las hojas de los árboles. *Mandorla. "Almond" in Italian. This form has great significance in the art world. Its shape comes from two intersecting circles. It represents the way between the two worlds, the earthly and the celestial. Also the leaves of the trees.*



Luna. Es un relieve inspirado en el único satélite natural que tiene la tierra, la luna. Su desplazamiento dentro del azulejo representa el movimiento de la misma en el cielo. *Luna. It is a relief inspired by the only natural satellite of the earth, the moon. Its displacement inside the tile represents the movement of it in the sky.*



Aria. El nombre de este relieve también proviene del italiano, y significa "Aire". Sus formas evocan a las aspas de los molinos de viento. *Aria. The name of this relief also comes from the Italian language, and means "Air". Its shapes evoke the blades of the windmills.*



Bivio. En italiano "Cruce de caminos". Este relieve tiene como protagonista las intersecciones, puntos de unión que a veces unen y otras separan. *Bivio. This word means in Italian "Crossroad". This relief has as protagonist the intersections, points of union that sometimes join and, other times, separate.*



187418 Bivio Bronzo 25x25 cm



187434 Shapes Luce 25x25 cm
187432 Aria Luce 25x25 cm



t187409 Luna White 25x25 cm
187328 Shapes White 25x25 cm



187424 Shapes Bronzo 25x25 cm
187421 Aria Bronzo 25x25 cm



187420 Mandorla Bronzo 25x25 cm



187432 Aria Luce 25x25 cm



SHAPES

187408 Bivio Panna 25x25 cm

SHAPES



187433 Luna Luce 25x25 cm

187412 Mandorla White 25x25 cm



187328 Shapes White 25x25 cm
187409 Luna White 25x25 cm
187424 Shapes Bronzo 25x25 cm
187419 Luna Bronzo 25x25 cm



187328 Shapes White 25x25 cm
187412 Mandorla White 25x25 cm





187432 Aria Luce 25x25 cm



187421 Aria Bronzo 25x25 cm



187439 Bivio Luce 25x25 cm

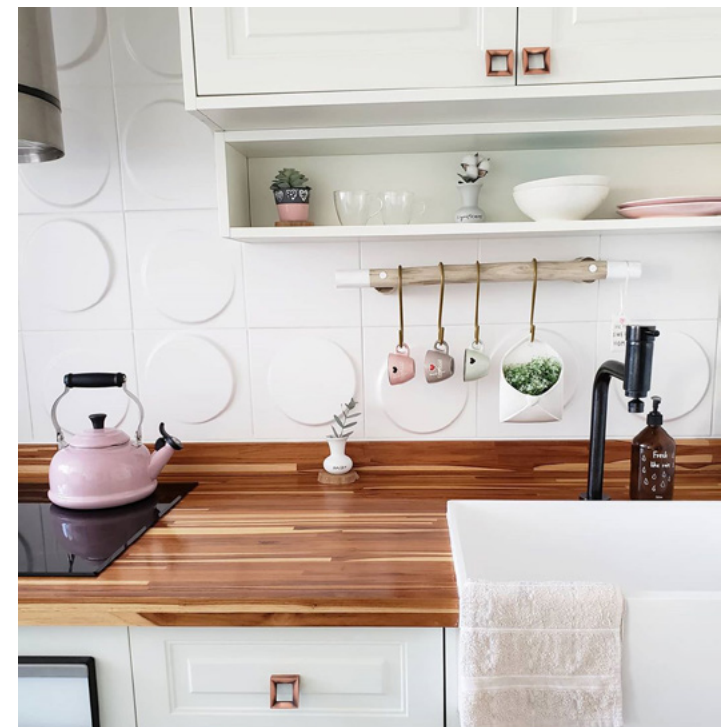

187409 Luna White 25x25 cm
187328 Shapes White 25x25 cm



187421 Aria Bronzo 25x25 cm

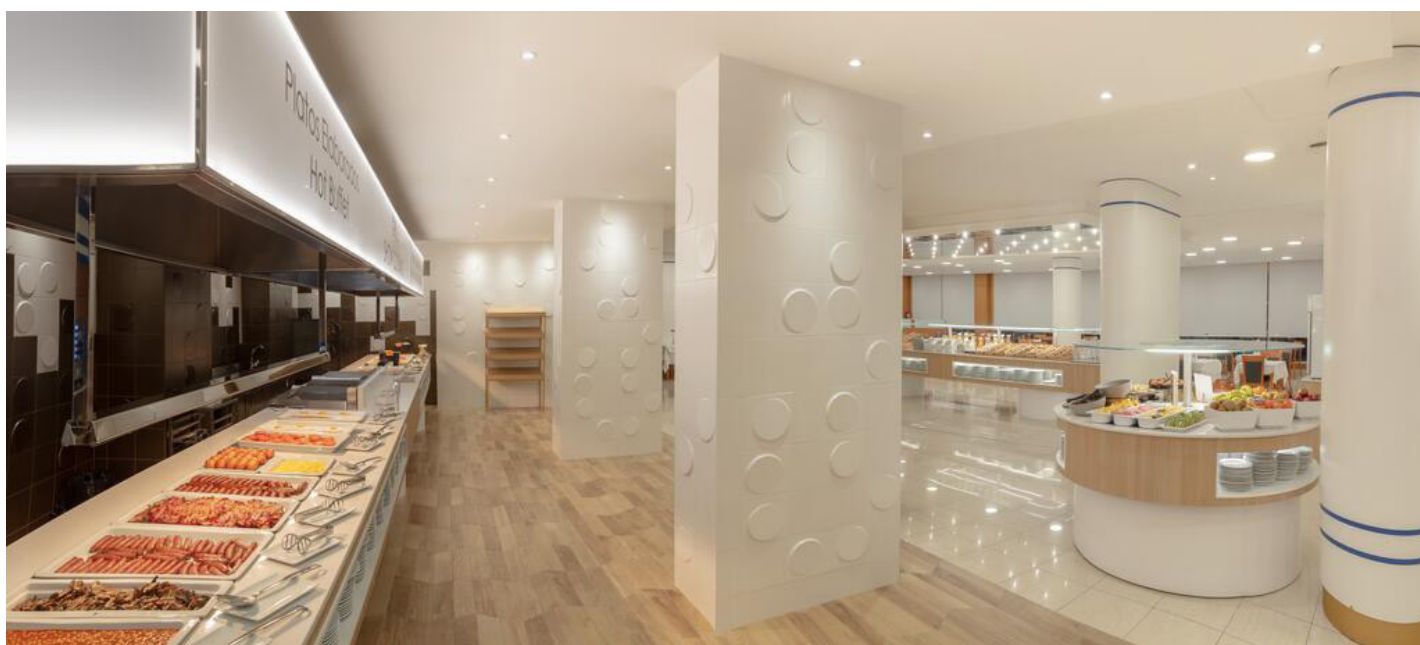

187409 Luna White 25x25 cm
187328 Shapes White 25x25 cm

SHAPES #3

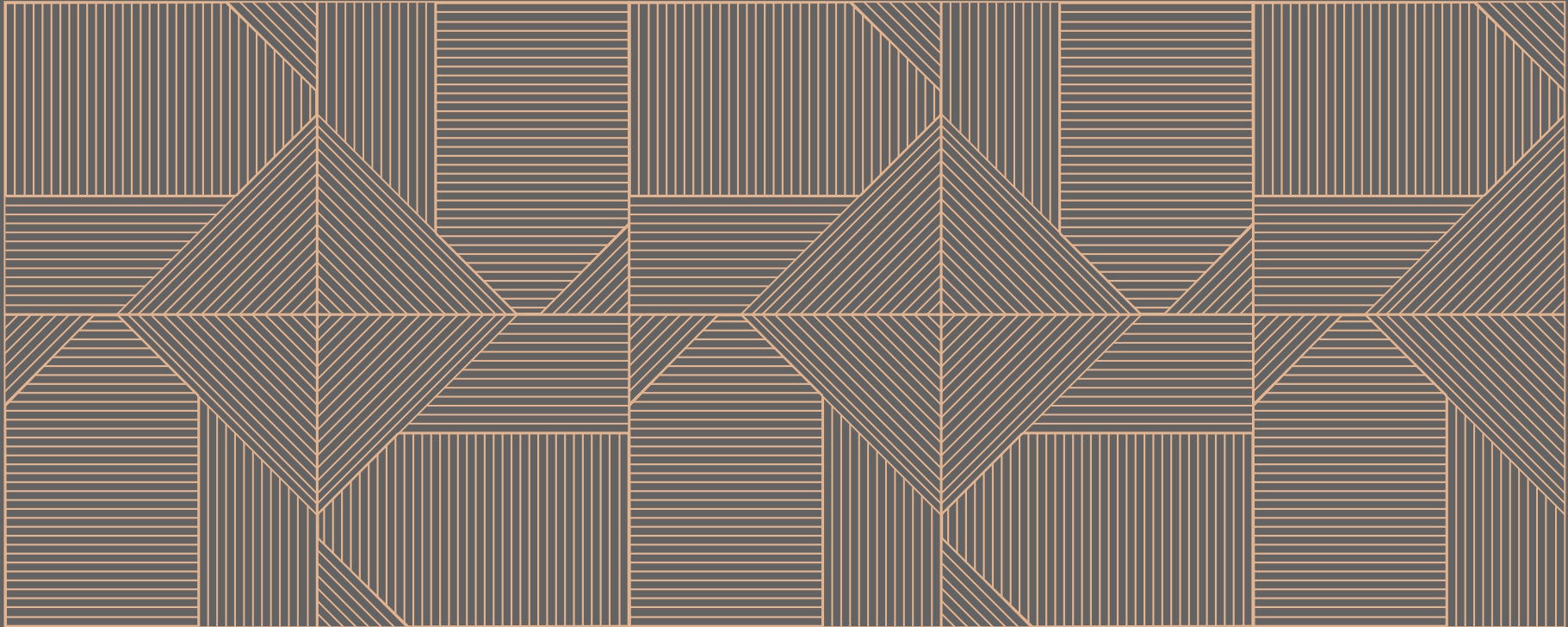

La sucesión continua de puntos da lugar a la línea, el grafismo más sencillo y puro, capaz de generar estructuras versátiles. STRIPES es una nueva serie surcada por finas líneas que recoge el lado más minimal y, a la vez, más rico que se puede lograr con esta simplicidad: con un simple giro de las piezas, generamos patrones cambiantes donde la luz juega con nuestros sentidos y nos hace ver matices cromáticos en cada una de sus secciones.

La inspiración de sus acabados tiene como eje central la naturaleza: maderas, bambú, mármol o metales generan superficies sorprendentes. Sus versiones textiles, de lino o el denim, nos acercan la calidez de los tejidos naturales.

In the simplest and purest graphic form rises a line versatile for many structures. STRIPES is a new series where fine lines cover the surface of the tiles, expressing the most minimal side of this pattern while achieving its richest aesthetic through simplicity. By the turn of each piece, we generate changing patterns where the light plays with our senses by showing nuances in its design.

The inspiration of its finishes comes from nature: wood, bamboo, marble or metals generate surprising compositions. The textile inspired denim and linen bring us closer to the warmth of natural fabrics.

#3

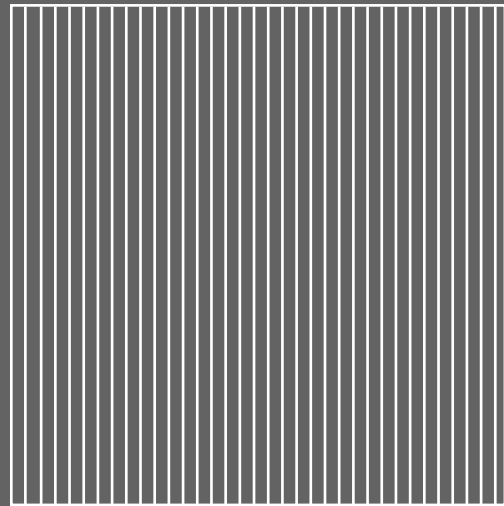

stripes

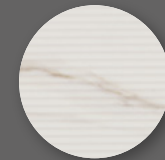

calacatta



bamboo



teak

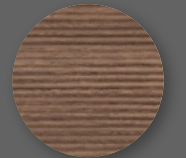

oak

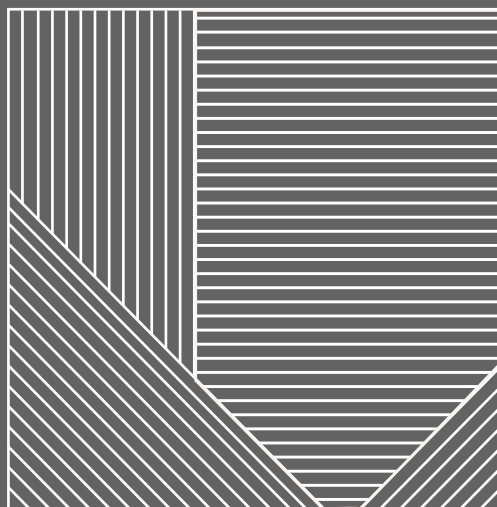

stripes mix



linen



denim

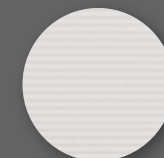

glacier

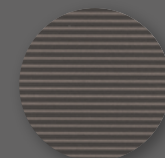

mercury



copper

SHAPES #3

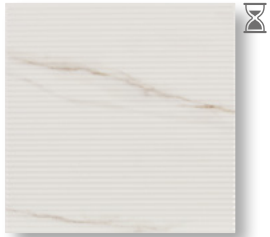

187596 Stripes Calacatta
25x25 cm./9.8"x9.8" M960

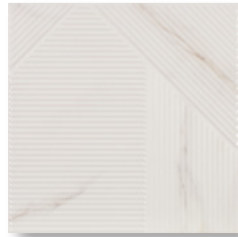

187599 Stripes Mix Calacatta
25x25 cm./9.8"x9.8" M960

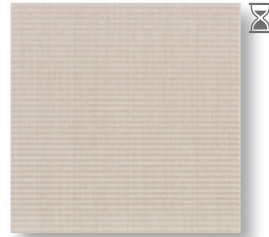

187560 Stripes Linen
25x25 cm./9.8"x9.8" M960



187562 Stripes Mix Linen
25x25 cm./9.8"x9.8" M960



187561 Stripes Denim
25x25 cm./9.8"x9.8" M960



187563 Stripes Mix Denim
25x25 cm./9.8"x9.8" M960

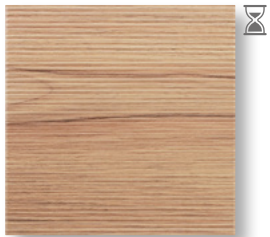

187543 Stripes Teak
25x25 cm./9.8"x9.8" M960



187546 Stripes Mix Teak
25x25 cm./9.8"x9.8" M960

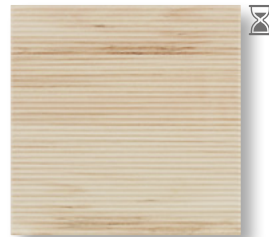

187544 Stripes Bamboo
25x25 cm./9.8"x9.8" M960



187547 Stripes Mix Bamboo
25x25 cm./9.8"x9.8" M960



187545 Stripes Oak
25x25 cm./9.8"x9.8" M960



187548 Stripes Mix Oak
25x25 cm./9.8"x9.8" M960

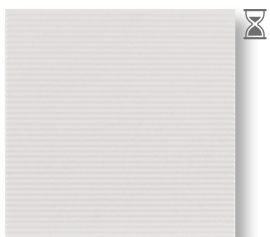

187564 Stripes Glacier
25x25 cm./9.8"x9.8" M963

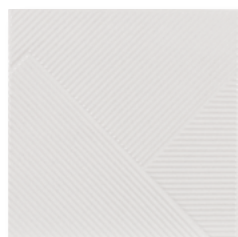

187558 Stripes Mix Glacier
25x25 cm./9.8"x9.8" M963

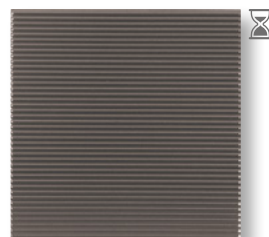

187565 Stripes Mercury
25x25 cm./9.8"x9.8" M963

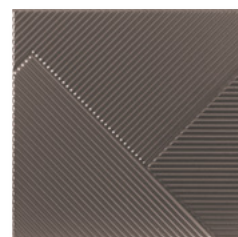

187559 Stripes Mix Mercury
25x25 cm./9.8"x9.8" M963

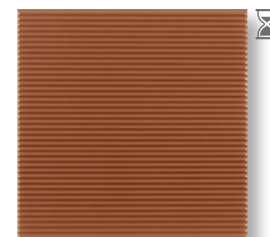

187566 Stripes Copper
25x25 cm./9.8"x9.8" M963

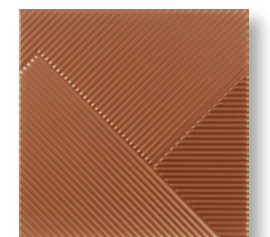

187557 Stripes Mix Copper
25x25 cm./9.8"x9.8" M963





La naturalidad del lino o el carácter juvenil del denim, dos diseños textiles para ambientes cálidos y acogedores, tanto en su versión lisa como en patchwork.

The natural feel of linen and the youthful character of denim create two dynamic textile designs that add warmth while creating welcoming environments. Create endless combinations and patterns with plain or mixed patchwork designs.

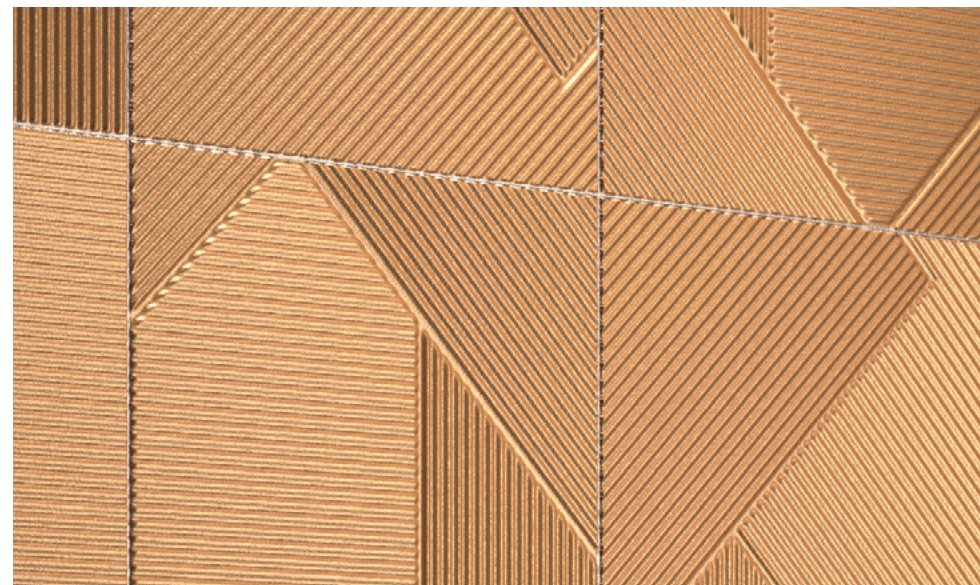

Glacier, una propuesta en blanco metalizado para espacios delicados y elegantes, que evoca a los destellos de luz sobre paisajes polares. La propuesta metálica de Stripes se completa con Mercury y Copper.

Glacier, a white reflective finish for delicate and elegant spaces, evokes the flashes of light on polar landscapes. Stripes' metallic designs also encompass the beauty of Mercury and Copper.

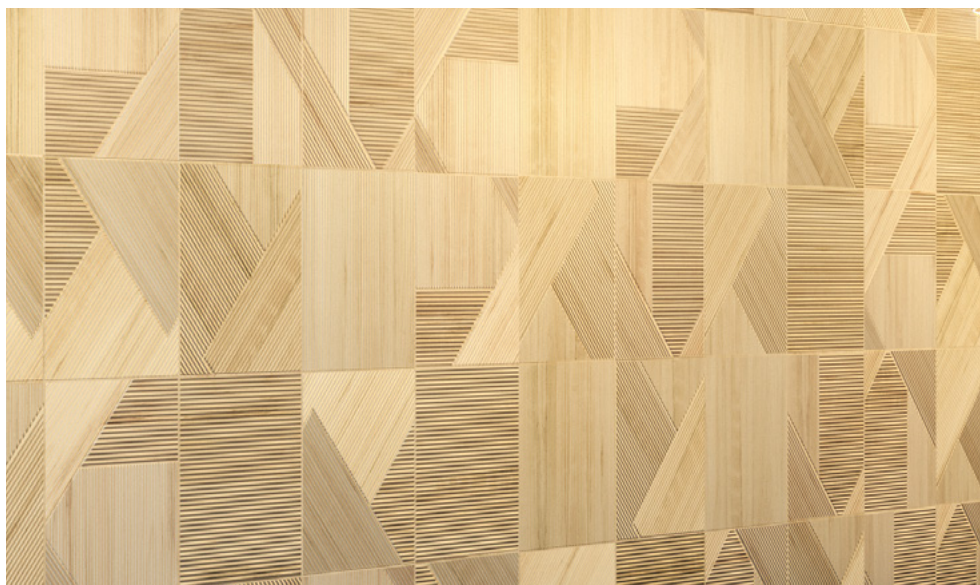

Teca, bambú o roble, tres texturas naturales plasmadas con gran realismo sobre los relieves Stripes, trasladan la calidez de la madera a cualquier espacio público o privado.

Teak, bamboo and oak are natural textures embodied with great realism on the Stripes series. They bring the warmth of wood to any public or private spaces.

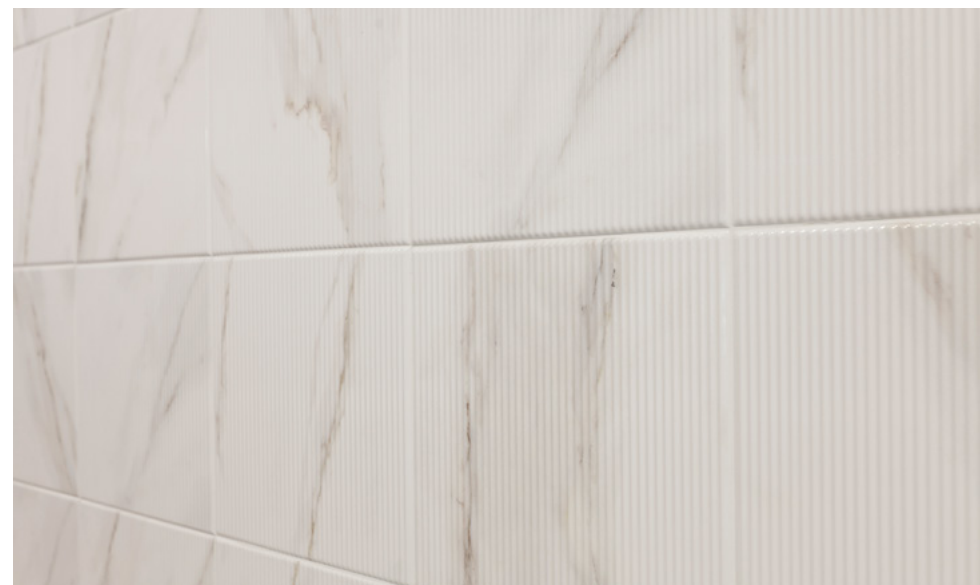

Un diseño único de mármol calacatta cubre superficies brillo y mate, generando sutiles cambios de luz.

A unique design of calacatta marble covers glossy and matt areas, creating subtle changes of light and shadows.



187560 Stripes Linen 25x25 cm
187562 Stripes Mix Linen 25x25 cm



187561 Stripes Denim 25x25 cm
187563 Stripes Mix Denim 25x25 cm

SHAPES

187566 Stripes Copper 25x25 cm
187557 Stripes Mix Copper 25x25 cm





187564 Stripes Glacier 25x25 cm
187558 Stripes Mix Glacier 25x25 cm

SHAPES

187565 Stripes Mercury 25x25 cm
187559 Stripes Mix Mercury 25x25 cm



187596 Stripes Calacatta 25x25 cm
187599 Stripes Mix Calacatta 25x25 cm



187547 Stripes Mix Bamboo 25x25 cm



187560 Stripes Linen 25x25 cm
187562 Stripes Mix Linen 25x25 cm



187547 Stripes Mix Bamboo 25x25 cm
187544 Stripes Bamboo 25x25 cm



187564 Stripes Glacier 25x25 cm
187558 Stripes Mix Glacier 25x25 cm



Registro
Registration

rock spa



187543 Stripes Teak 25x25 cm
187546 Stripes Mix Teak 25x25 cm

SHAPES #4



TRANSVERSE es la serie más técnica de SHAPES, realizada en pequeño formato y porcelánico técnico, diseñada para construir espacios interiores y exteriores. Su belleza radica en la simplicidad de su diseño, con cuatro formas geométricas de grosor variable, que invitan a crear composiciones diversas, jugando con la posición de las piezas.

Colores neutros, líneas diagonales y lados que suben y bajan, así es TRANSVERSE inspirada en el minimalismo de la cerámica japonesa, donde la luz se recrea en los relieves, generando sutiles juegos de luces y sombras.

Clay, cement y graphite constituyen la gama cromática de Transverse, donde imperan el orden y la repetición, sólo alterables con toques de decoración que aportan cuatro propuestas basadas en la madera, los metales y los esmaltes de la cerámica artesanal.

TRANSVERSE, the most technical series of SHAPES, is a small format, full body porcelain designed for interior and exterior spaces. Its beauty lies in the simplicity of the design of four geometric shapes in irregular thickness which invite you to create diverse compositions.

Inspired by the minimalism of Japanese design, TRANSVERSE uses neutral colors with simple diagonal lines and varying thickness to interact with light. These reliefs generate subtle contrasts made by the shadows for a stunning design.

Clay, cement, and graphite make the palette of TRANSVERSE, where order and repetition prevail in its purest form. Dress up the design with matching decorative pieces inspired by wood, metals and handmade ceramics.

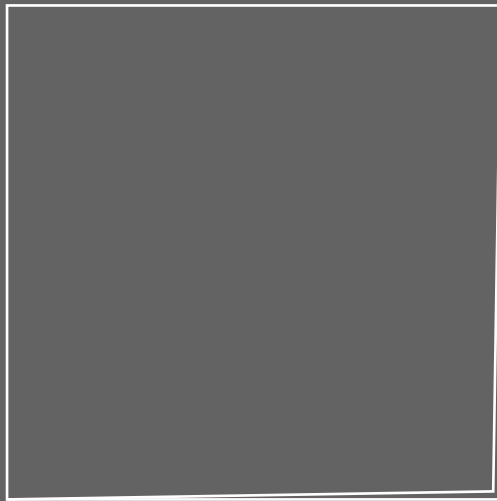

Transverse 1

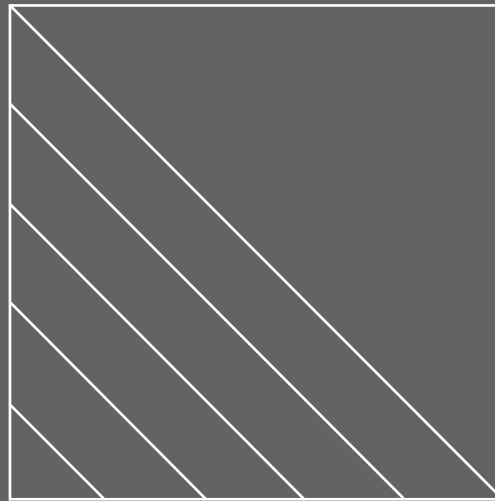

Transverse 2

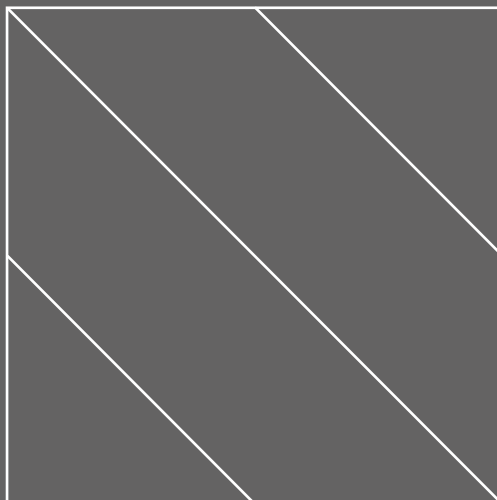

Transverse 4

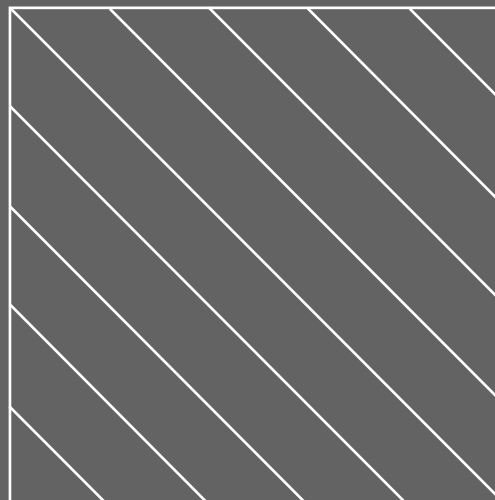

Transverse 3



clay



wood



cement



crackle

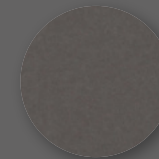

graphite



copper

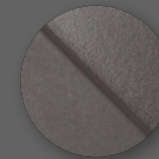

luce

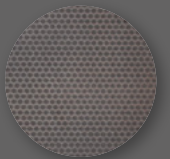

metal

SHAPES #4

PORCELAIN MATT V0    10 mm

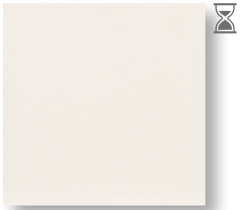

187574 Transverse 1 Clay
14,7×14,7 cm./5.8"×5.8" M963

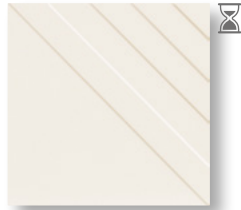

187578 Transverse 2 Clay
14,7×14,7 cm./5.8"×5.8" M963

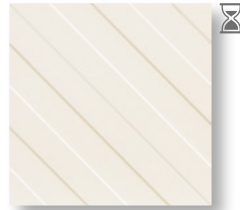

187571 Transverse 3 Clay
14,7×14,7 cm./5.8"×5.8" M963

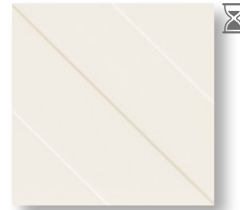

187580 Transverse 4 Clay
14,7×14,7 cm./5.8"×5.8" M963



187618 Transverse 2 Crackle
14,7×14,7 cm./5.8"×5.8" D55

SATIN V1 

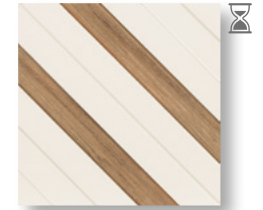

187617 Transverse 3 Wood
14,7×14,7 cm./5.8"×5.8" D55

MATT V1 

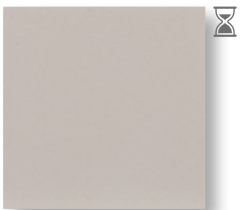

187575 Transverse 1 Cement
14,7×14,7 cm./5.8"×5.8" M963

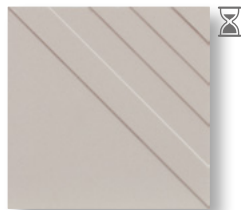

187579 Transverse 2 Cement
14,7×14,7 cm./5.8"×5.8" M963

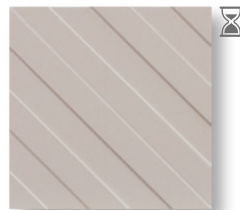

187572 Transverse 3 Cement
14,7×14,7 cm./5.8"×5.8" M963

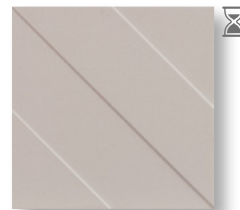

187581 Transverse 4 Cement
14,7×14,7 cm./5.8"×5.8" M963

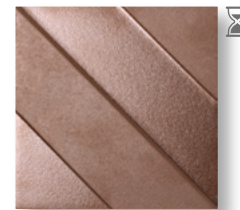

187610 Transverse 4 Copper
14,7×14,7 cm./5.8"×5.8" D280

SATIN V1 PVD

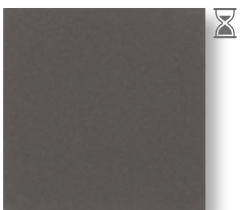

187576 Transverse 1 Graphite
14,7×14,7 cm./5.8"×5.8" M963

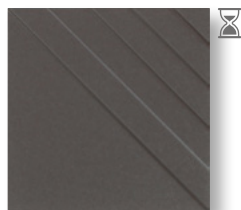

187577 Transverse 2 Graphite
14,7×14,7 cm./5.8"×5.8" M963

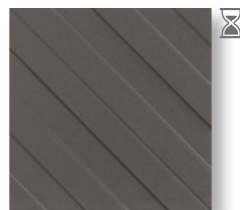

187573 Transverse 3 Graphite
14,7×14,7 cm./5.8"×5.8" M963

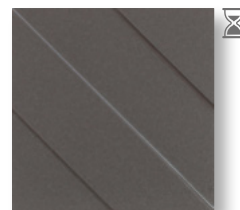

187582 Transverse 4 Graphite
14,7×14,7 cm./5.8"×5.8" M963

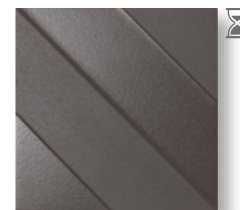

187628 Transverse 4 Luce
14,7×14,7 cm./5.8"×5.8" M976

SATIN

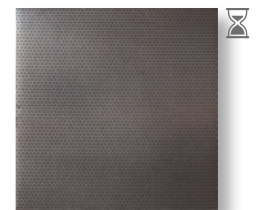

187627 Transverse 1 Metal
14,7×14,7 cm./5.8"×5.8" D55

GLOSS V1 

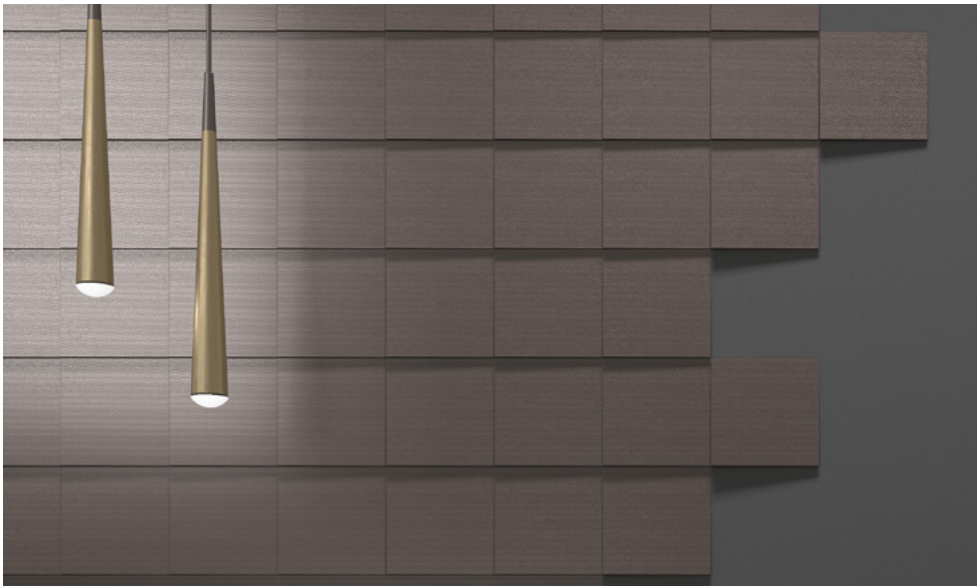

Una suave pendiente es la esencia de Transverse 1 realizado con porcelánico técnico. Su aparente simplicidad esconde una invitación a crear patrones distintos, levantando y hundiendo las esquinas, a través del giro de las piezas. *A smooth slope is the essence of Transverse 1 full body porcelain relief. Behind its apparent simplicity hides an invitation to create different patterns with just a turn of the tile due to the varying thickness of its corners.*



Transverse 2. Dos planos simétricos, uno liso y otro surcado por diagonales, descienden desde los extremos hasta converger en el centro de la pieza, dejando a la vista ángulos y bordes que se integran en el diseño, enriqueciendo el conjunto. *Transverse 2. Two symmetrical planes descend from extremes to converge in the center of each piece where one plane is flat while the other is crossed by diagonals. The result is the angles and edges that play a key role in the design of this series.*



Transverse 3. Relieve con espesor regular y líneas diagonales paralelas, para crear patrones abiertos o cerrados de espigas, rombos y líneas, siempre con gran equilibrio. *Transverse 3. Uniformed in thickness, this relief with parallel diagonal lines create open or closed patterns of chevrons, diamonds or lines. These classic designs are always pure and balanced.*



Transverse 4. Azulejo de espesor regular y depurado diseño, con amplias franjas que recorren la pieza en diagonal para crear formas en zig-zag, rombo, líneas o patrones abiertos de gran belleza. *Transverse 4. Wide stripes diagonally intersect the surface to create simple but sophisticated patterns. Create chevrons, diamonds, rhombus or linear designs for classic and grand beauty.*



187575 Transverse 1 Cement 14,7×14,7 cm

SHAPES



187574 Transverse 1 Clay 14,7x14,7 cm

187574 Transverse 1 Clay 14,7×14,7 cm
187578 Transverse 2 Clay 14,7×14,7 cm
187571 Transverse 3 Clay 14,7×14,7 cm
187577 Transverse 2 Graphite 14,7×14,7 cm

MON
LOUNGE



Airline

187572 Transverse 3 Cement 14,7x14,7 cm

187578 Transverse 2 Clay 14,7×14,7 cm
187618 Transverse 2 Crackle 14,7×14,7 cm

SHAPES



187582 Transverse 4 Graphite 14,7×14,7 cm



187580 Transverse 4 Clay 14,7×14,7 cm



187571 Transverse 3 Clay 14,7×14,7 cm
187617 Transverse 3 Wood 14,7×14,7 cm

SHAPES



187610 Transverse 4 Copper 14,7×14,7 cm
187628 Transverse 4 Luce 14,7×14,7 cm



187578 Transverse 2 Clay 14,7×14,7 cm



SHAPES

187576 Transverse 1 Graphite 14,7×14,7 cm
187577 Transverse 2 Graphite 14,7×14,7 cm

SHAPES

187574 Transverse 1 Clay 14,7×14,7 cm
187578 Transverse 2 Clay 14,7×14,7 cm
187571 Transverse 3 Clay 14,7×14,7 cm

- 
- 187588 Organza 30x90cm
 - 187520 Cremabella 30x90cm
 - 187532 Cremabella Rec 60x120cm
 - 187605 Lavabo Eleganza Oro 42x42x12,5cm
 - 187587 Mosaico Cremabella 29,5x32cm

SHAPES #5

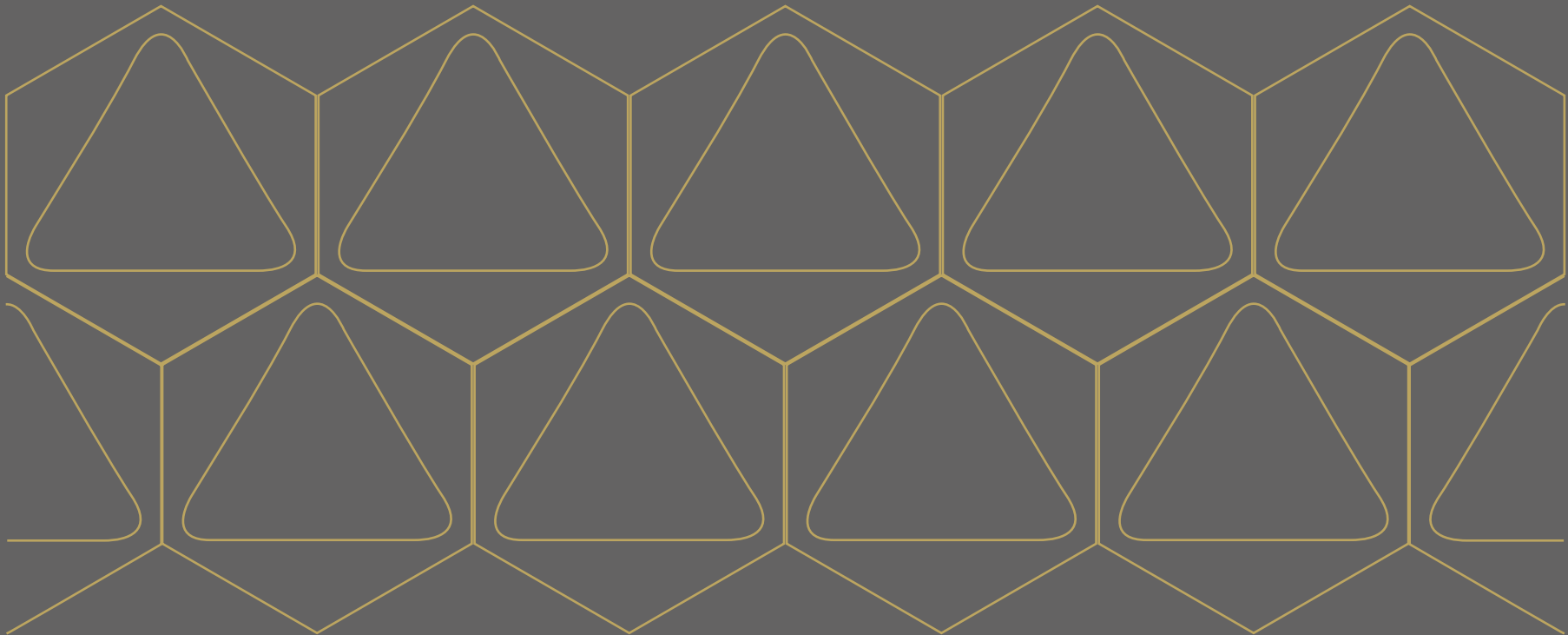

SHAPES#5 es la serie más glamourosa de SHAPES. Basada en la forma y el volumen, las líneas hexagonales y acabados metalizados cobran el protagonismo para vestir los espacios más modernos y enérgicos.

Los juegos geométricos de LONDON, MAJESTIC y HEXALINE forman parte de una tendencia de decoración muy en boga. Decorados atemporales hechos para ser combinados entre sí y experimentar con su colocación para crear magníficos juegos de luz y formas. Los modelos de SHAPES#5 son complementos decorativos perfectos para crear combinaciones únicas con increíbles macro-mosaicos.

SHAPES # 5 is the most glamorous series of SHAPES. It is based on the shape and volume and its hexagonal lines and metallic finishes take on special importance when dressing the most modern and energetic spaces.

The geometric games of LONDON, MAJESTIC and HEXALINE are part of a very fashionable decoration trend. Timeless decorations that are made to be combined with each other and experimented with their placement to create magnificent plays of light and shapes. SHAPES # 5 models are decorative complements that are perfectly suitable to create unique combinations with incredible macro-mosaics.

#5

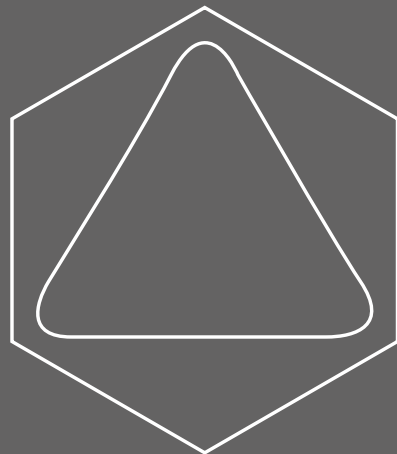

London

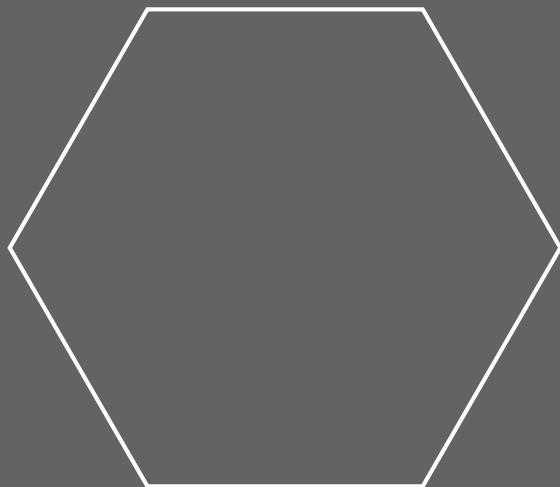

Hexaline

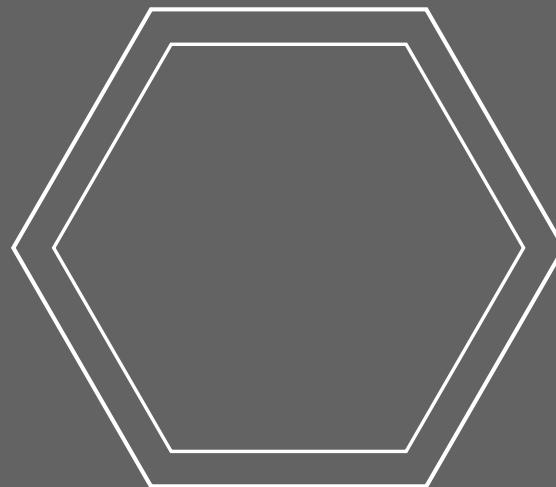

Majestic Decor



white



nacar

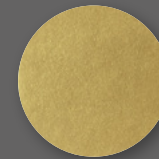

golden

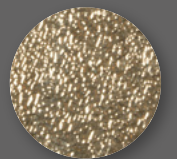

gold

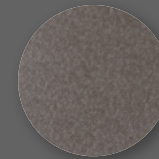

titanium

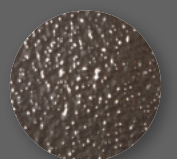

metal



gold & white

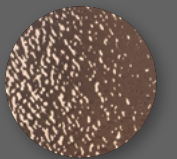

rose gold

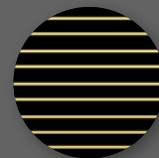

gold & black

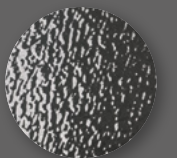

chrome

SHAPES #5

LONDON



188078 London Golden
16x18 cm./6.3"x7.1" M976

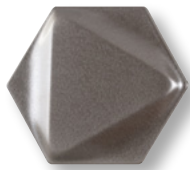

188079 London Titanium
16x18 cm./6.3"x7.1" M976



188077 London White
16x18 cm./6.3"x7.1" M941

HEXALINE



188000 Hexaline White
21,5x25 cm./8.5"x9.8" M895

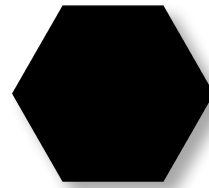

188001 Hexaline Black
21,5x25 cm./8.5"x9.8" M895



187998 Hexaline Comb White
21,5x25 cm./8.5"x9.8" D173

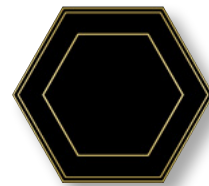

187999 Hexaline Comb Black
21,5x25 cm./8.5"x9.8" D173



188002 Hexaline Mix White
21,5x25 cm./8.5"x9.8" D260



188003 Hexaline Mix Black
21,5x25 cm./8.5"x9.8" D260



MAJESTIC

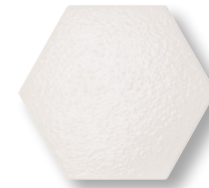

188005 Majestic Nacar
23x27 cm./9.1"x10.6" M927



188006 Majestic Decor Nacar
23x27 cm./9.1"x10.6" M927

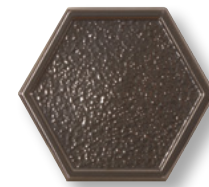

188007 Majestic Decor Metal
23x27 cm./9.1"x10.6" M940

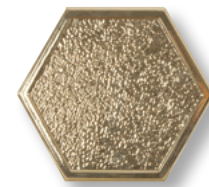

188027 Majestic Decor Gold
23x27 cm./9.1"x10.6" D280

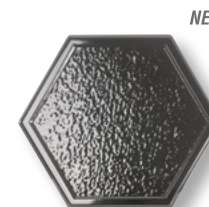

188211 Majestic Decor Chrome
23x27 cm./9.1"x10.6" D370

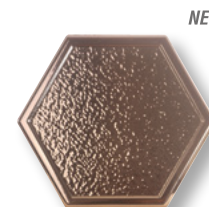

188212 Majestic Decor Rose Gold
23x27 cm./9.1"x10.6" D370



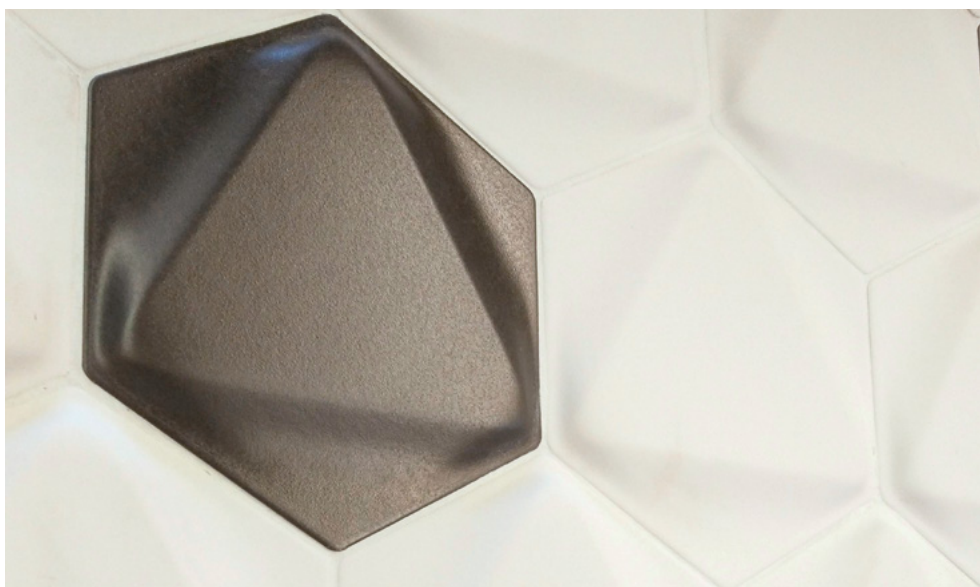

London...

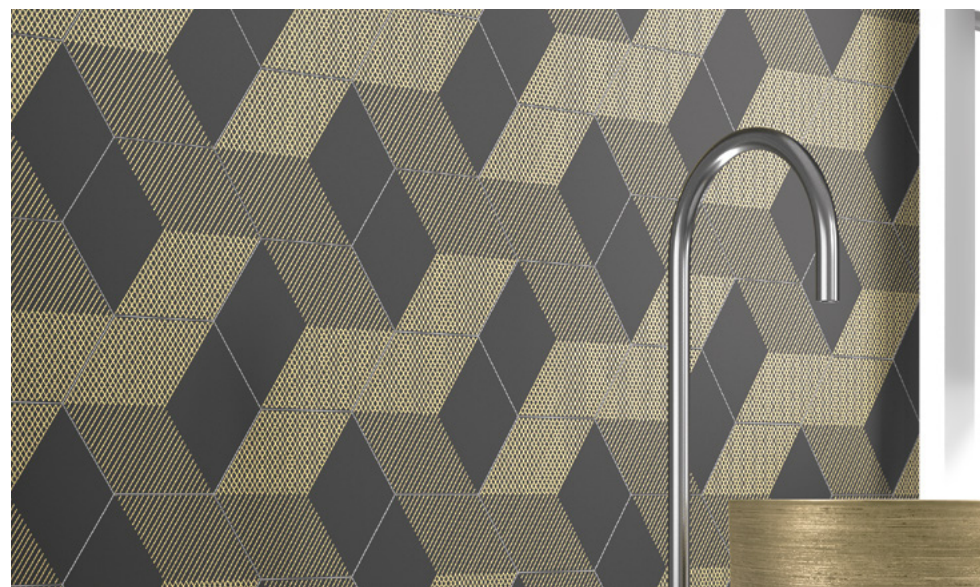

Hexaline...



Majestic...

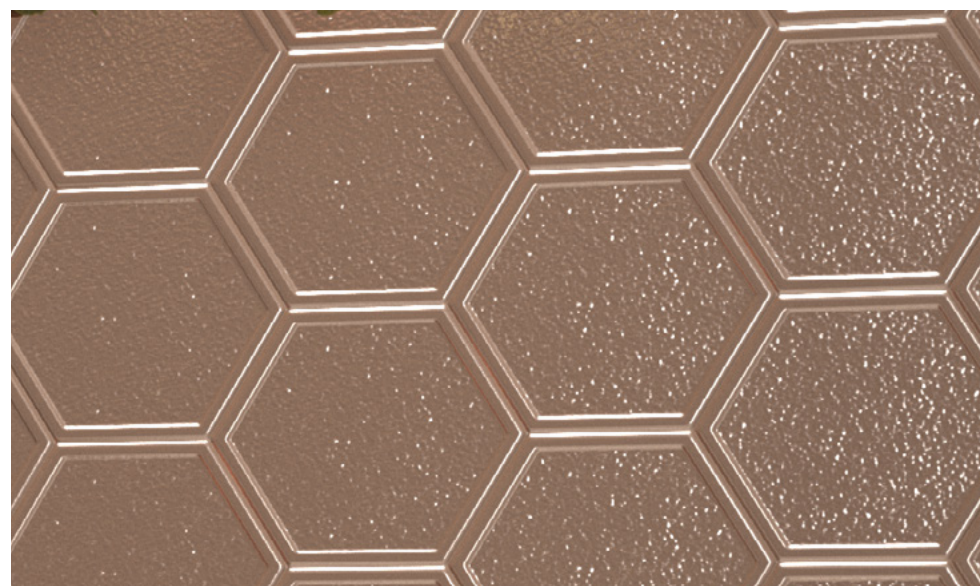

Nuevos colores Majestic...



188078 London Golden 16×18 cm
188079 London Titanium 16×18 cm
188077 London White 16×18 cm

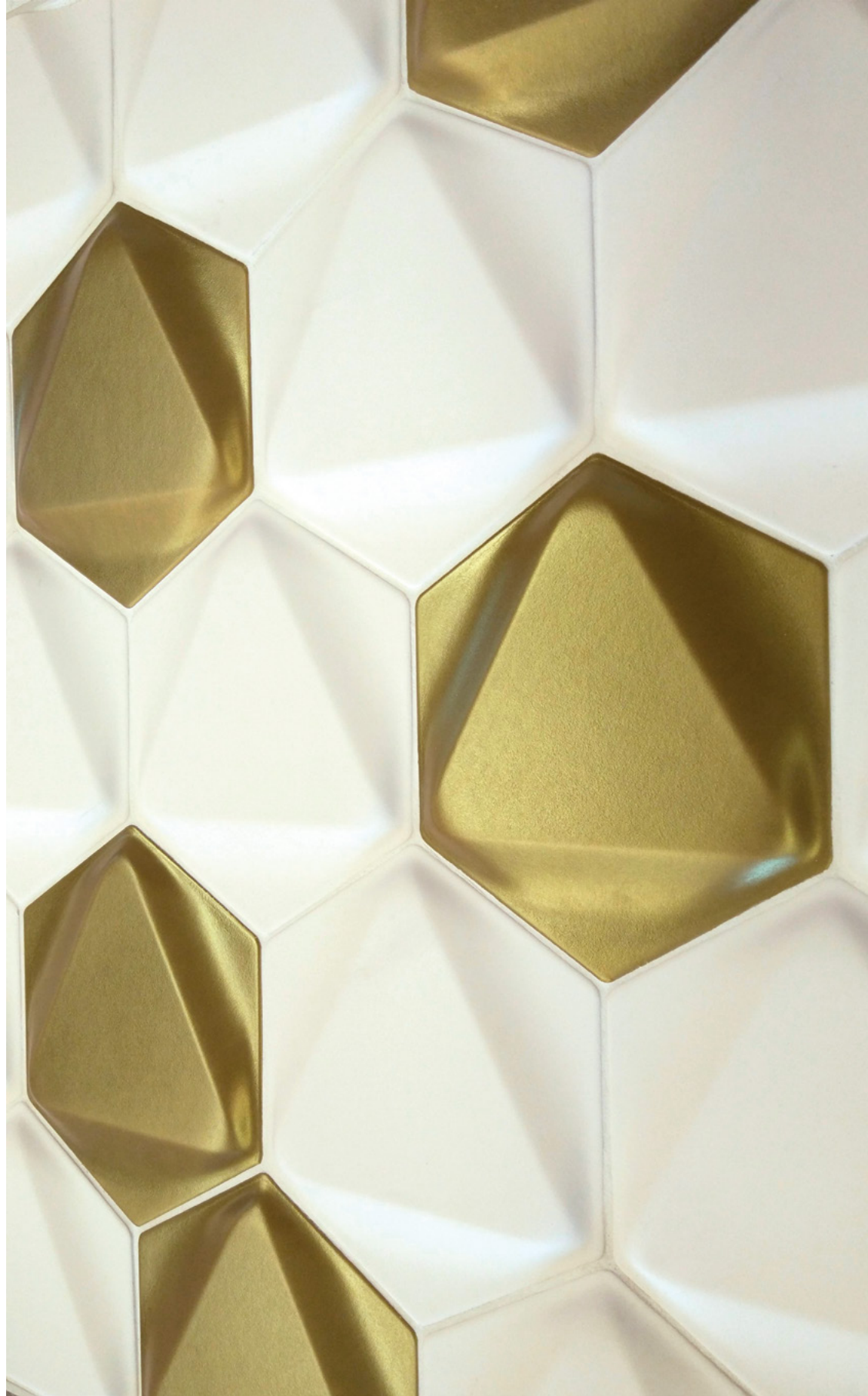

188078 London Golden 16x18 cm
188077 London White 16x18cm



187998 Hexaline Comb White 21,5×25 cm
188000 Hexaline White 21,5×25 cm
188012 Lavabo Selene Light Gold 40,5×40,5×15 cm



SHAPES

188001 Hexaline Black 21,5x25 cm
188003 Hexaline Mix Black 21,5x25 cm
188011 Lavabo Heller White & Gold 36x36x12 cm



188007 Majestic Decor Metal 23x27 cm
188006 Majestic Decor Nacar 23x27 cm

SHAPES



- 188011 Lavabo Heller White & Gold 36×36×12 cm
- 188027 Majestic Decor Gold 23×27 cm
- 188006 Majestic Decor Nacar 23×27 cm
- 188005 Majestic Nacar 23×27 cm
- 187949 Selene Light 30×90 cm
- 187953 Selene Light 60×60 cm

ouley

LOUI XIII
Mar Rouley
LE ROMEOBAN

188203 Cremabella 90x90 cm
188212 Majestic Decor Rose Gold 23x27 cm



188211 Majestic Decor Chrome 23x27 cm

#1

Shapes

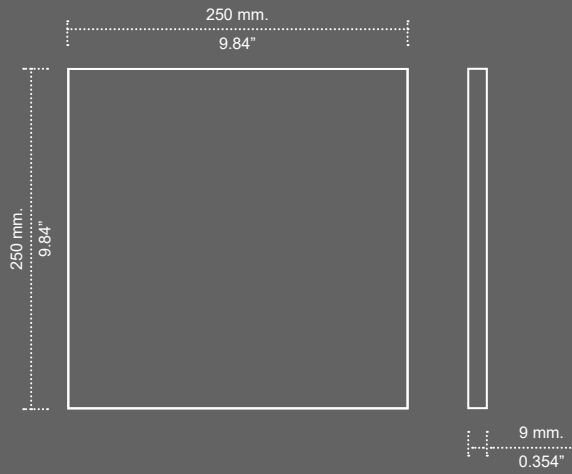

Japan

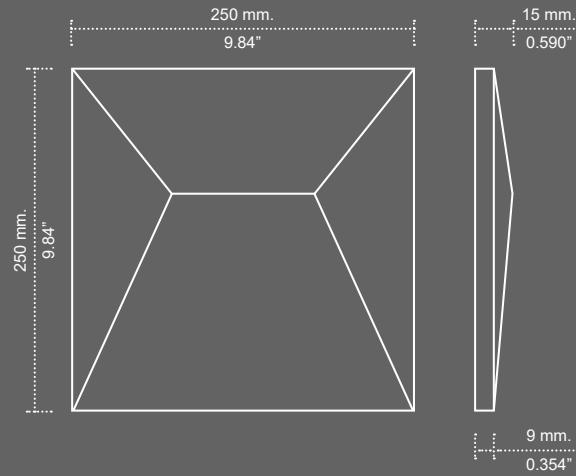

Origami

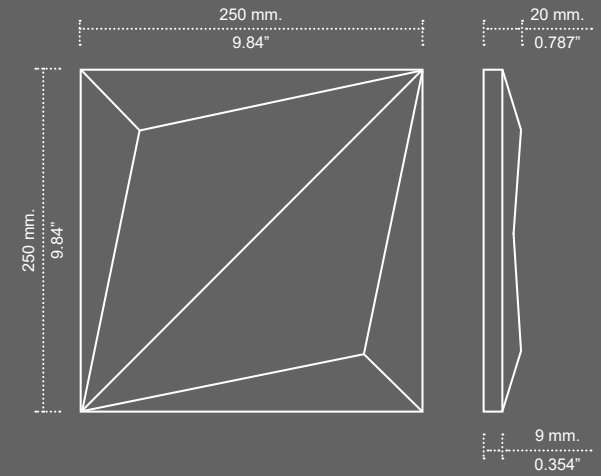

Kioto

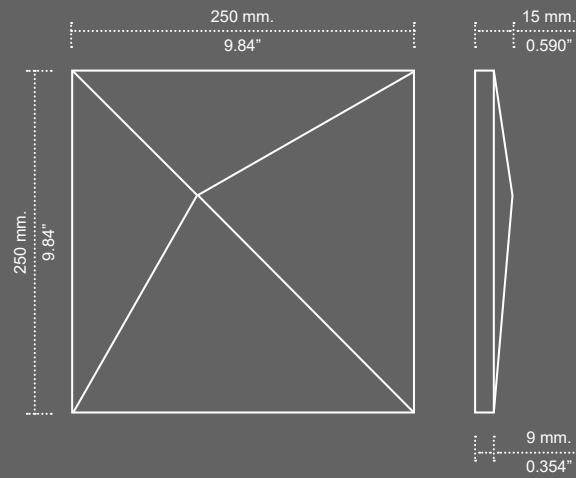

Multishapes

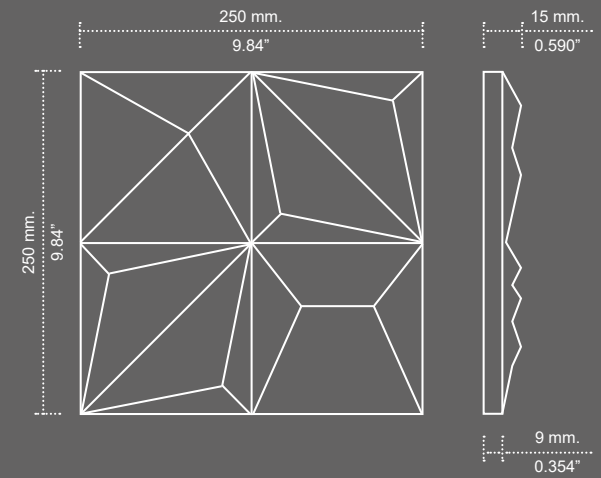

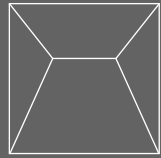

Japan

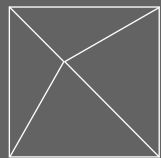
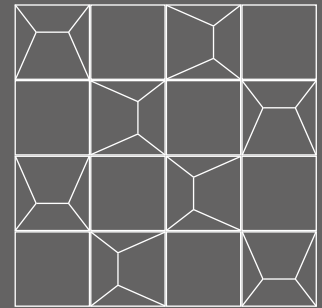
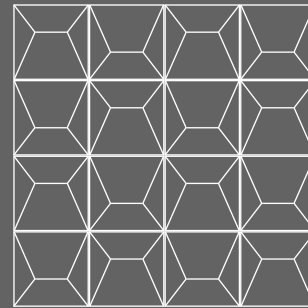
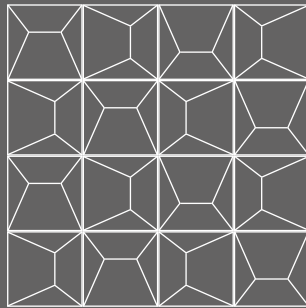
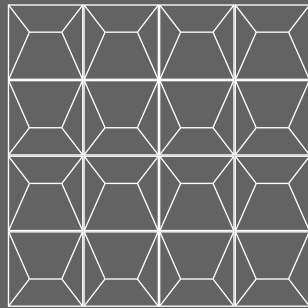

Kioto

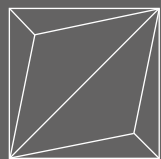
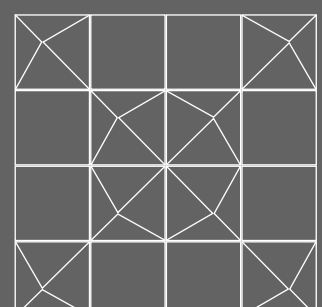
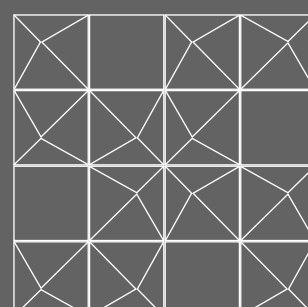
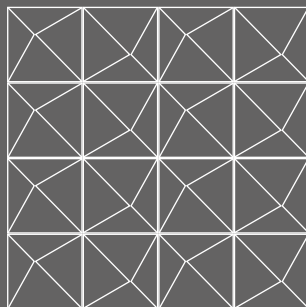
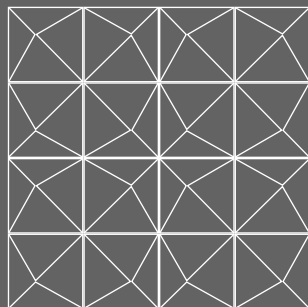

Origami

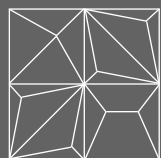
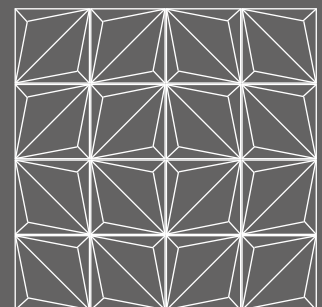
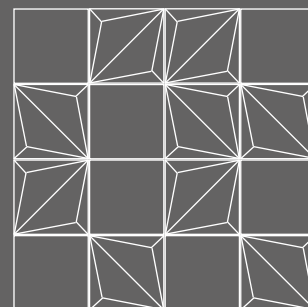
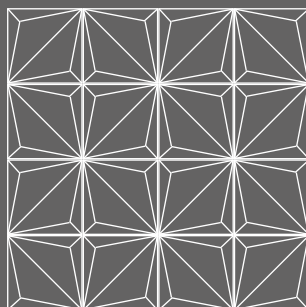
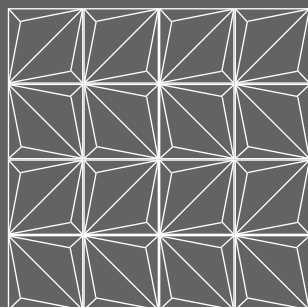

Multishapes

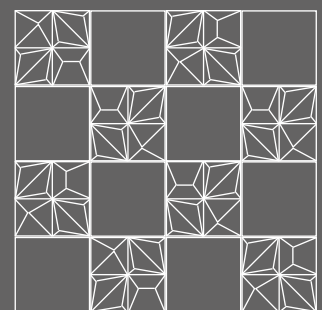
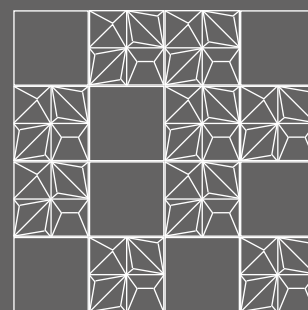
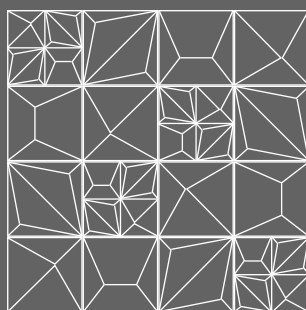
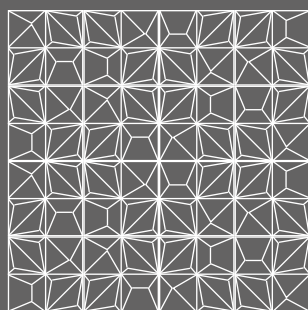

#2

Shapes

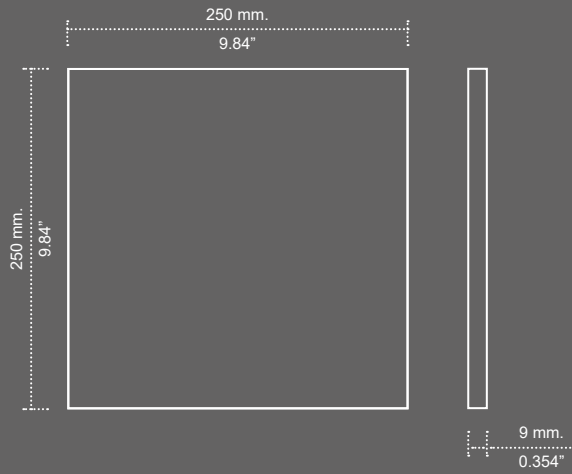

Luna

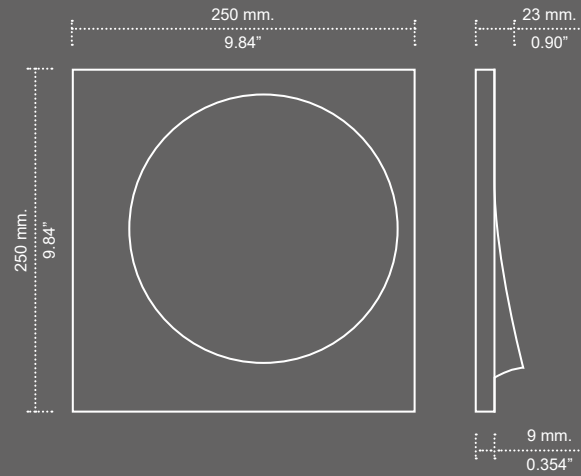

Bivio

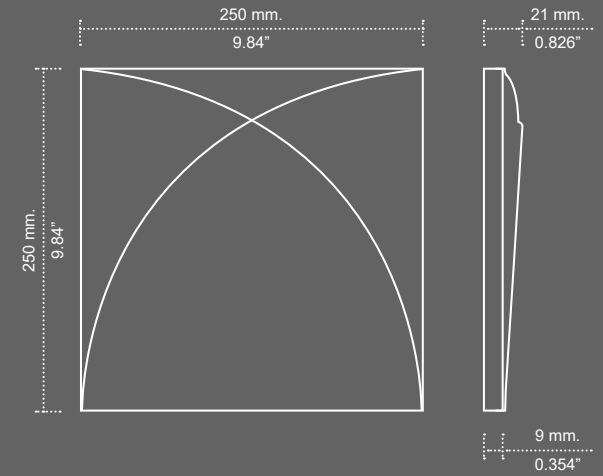

Aria

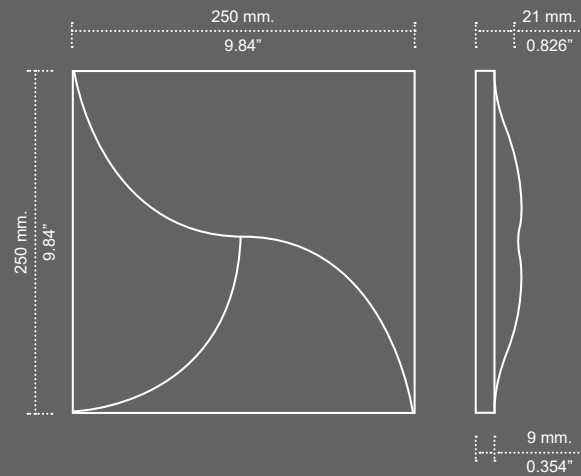

Mandorla

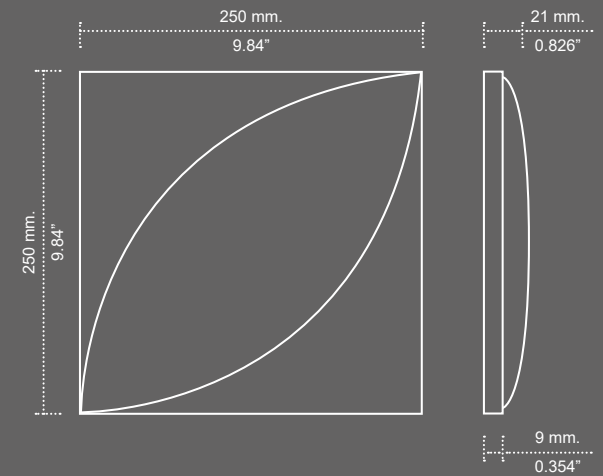

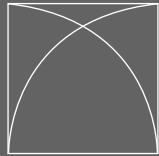

Bivio

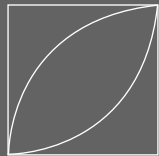
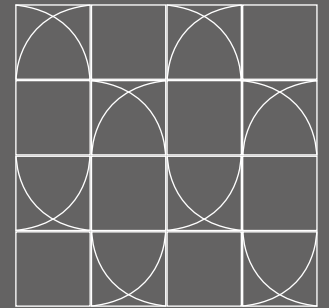
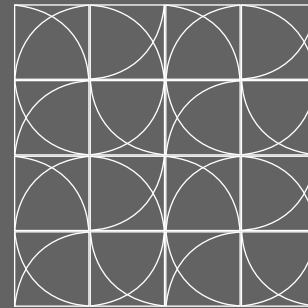
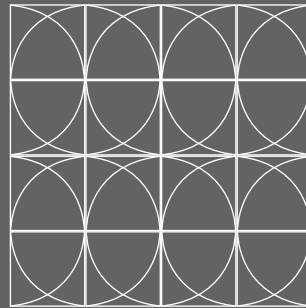
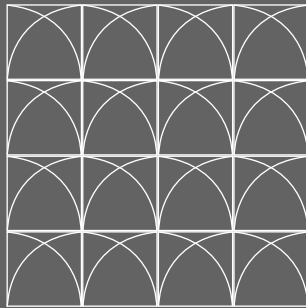

Mandorla

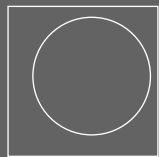
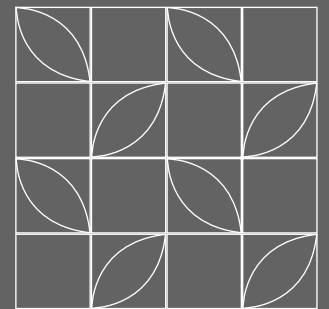
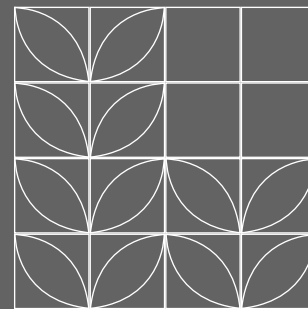
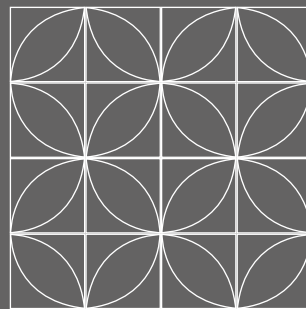
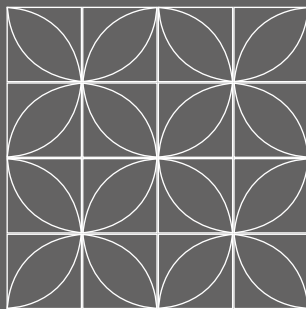

Luna

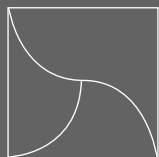
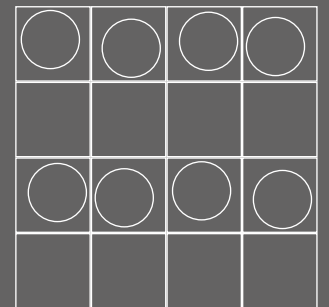
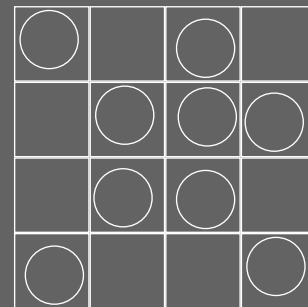
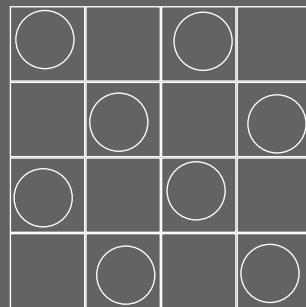
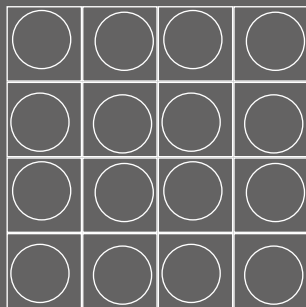

Aria

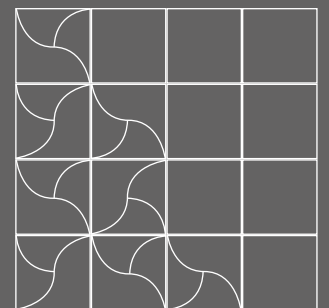
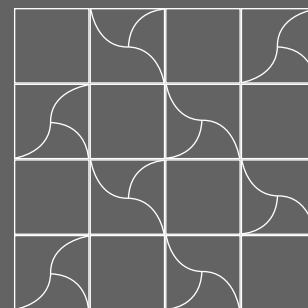
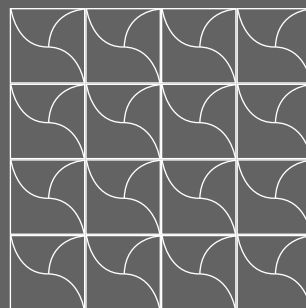
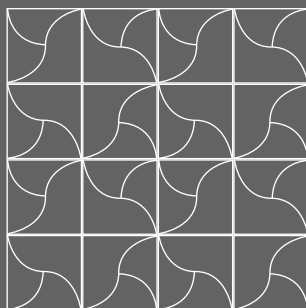

#3

Stripes

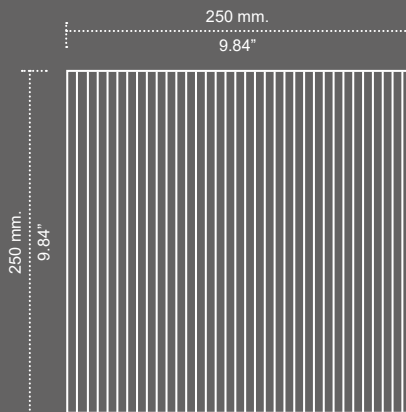

Stripes Mix

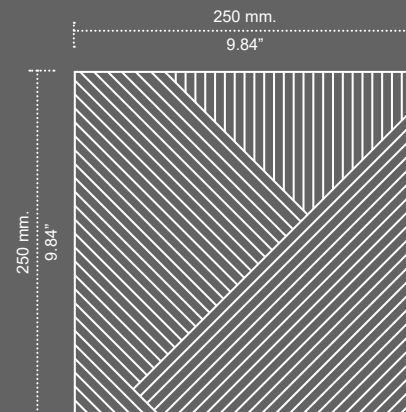
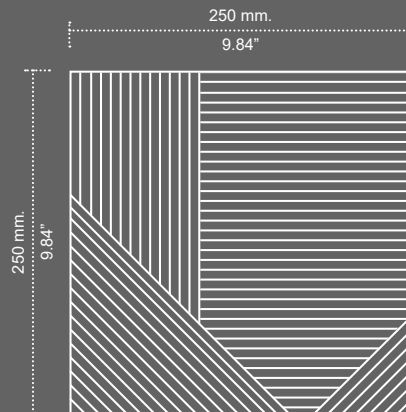

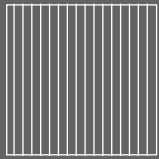

Stripes

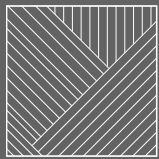
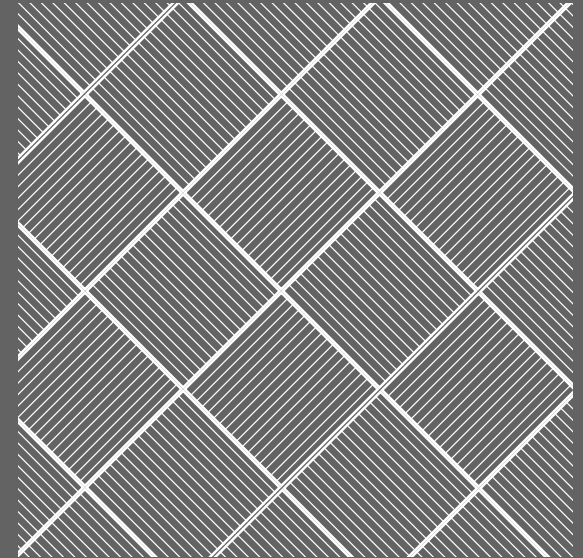
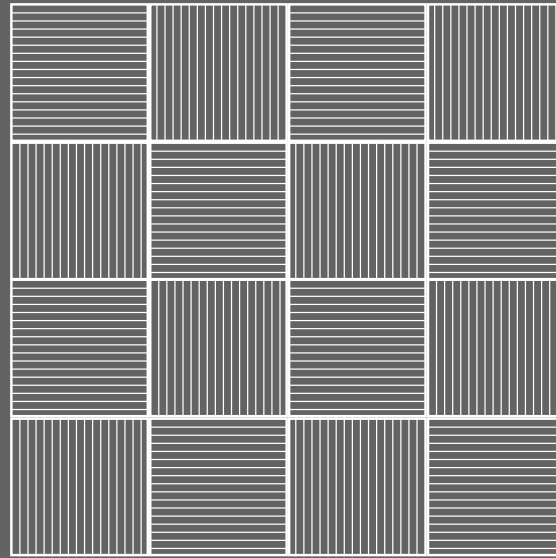
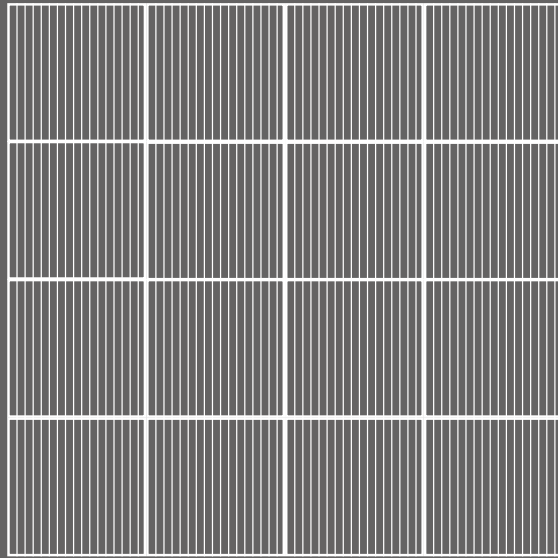

Stripes Mix

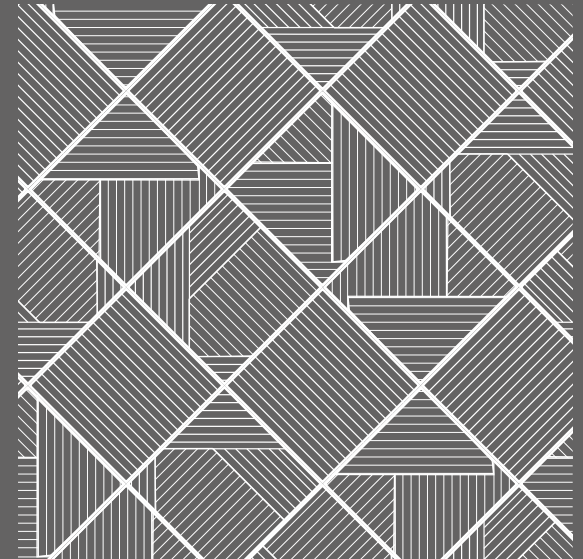
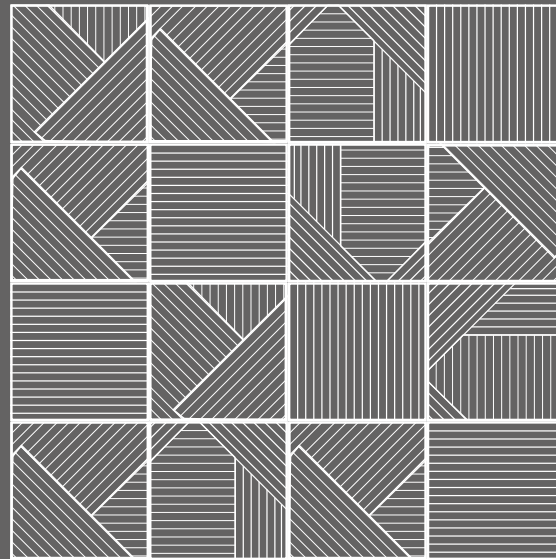
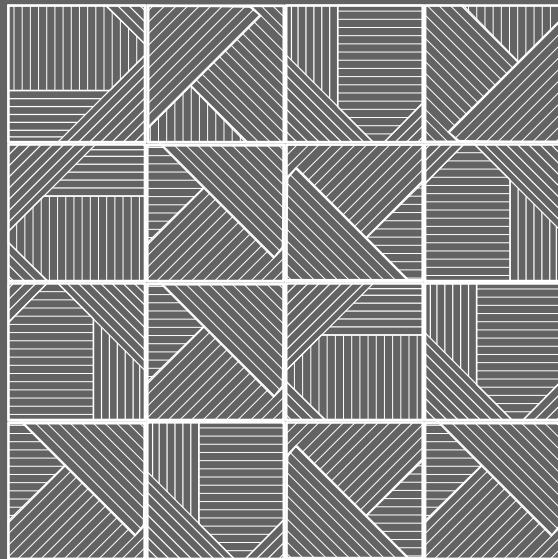

#4

Gres Porcelánico Técnico
Full Body Porcelain Tile

Absorción de agua
Water absorption

 < 0.5% Group BIa

Transverse 1

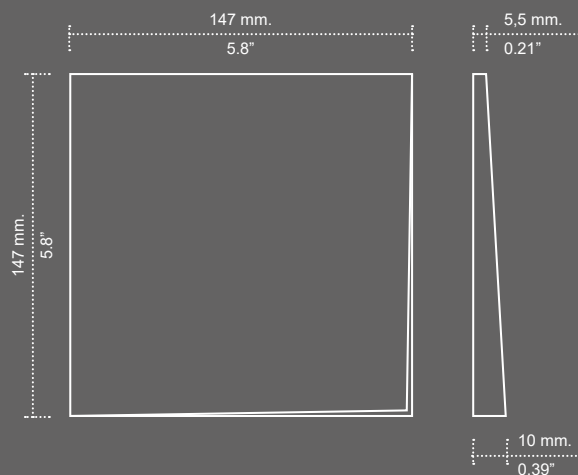

Transverse 2

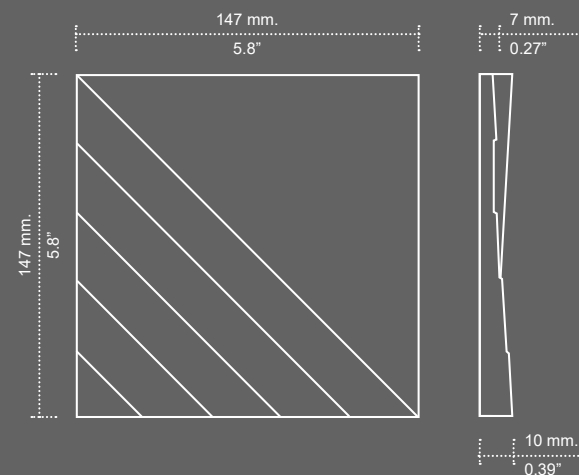

Transverse 3

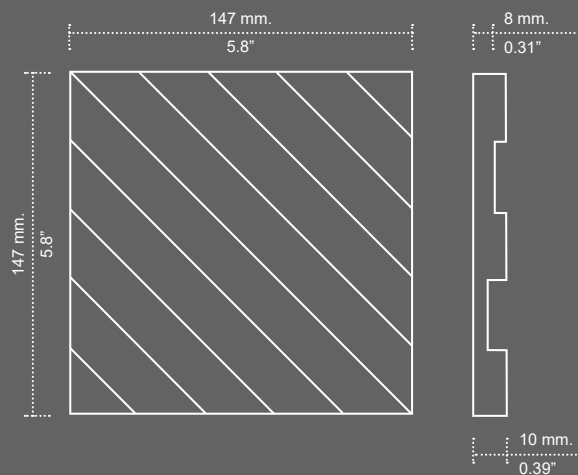

Transverse 4

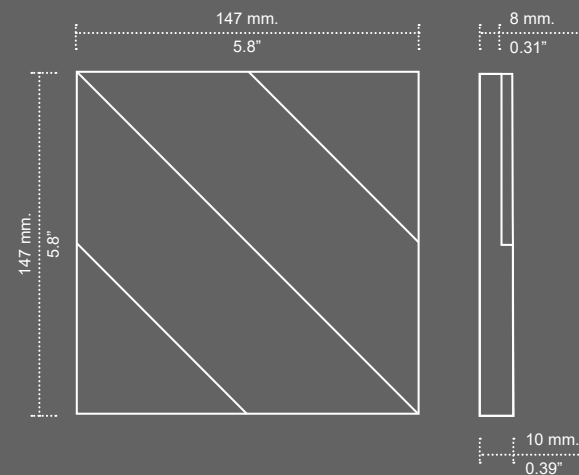

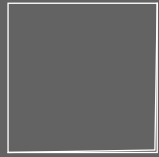

Transverse 1

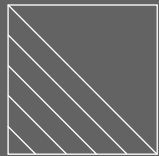
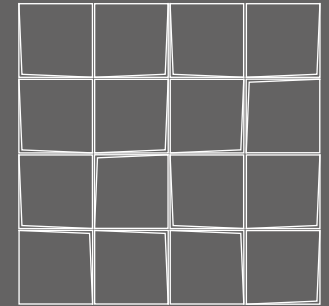
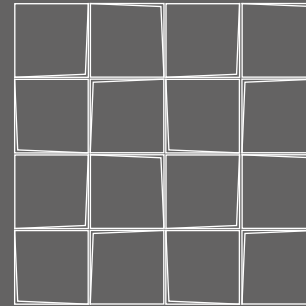
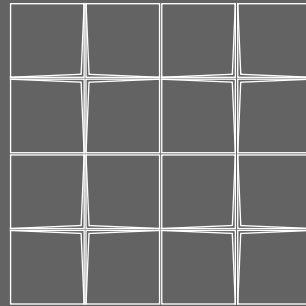
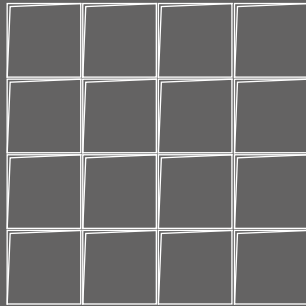

Transverse 2

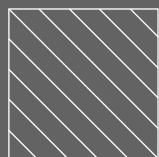
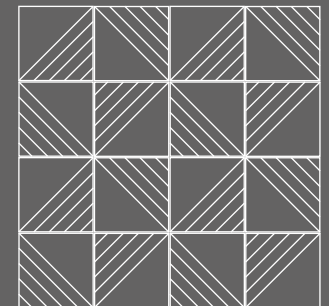
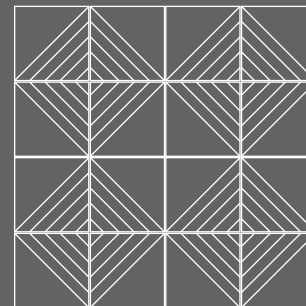
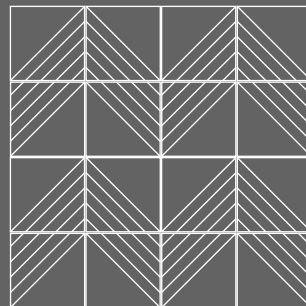
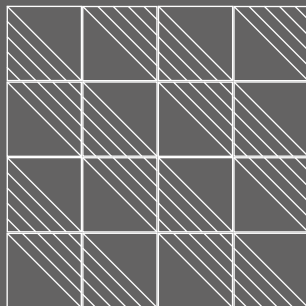

Transverse 3

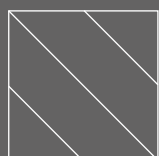
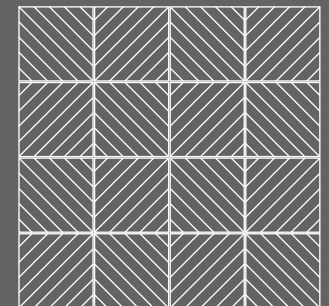
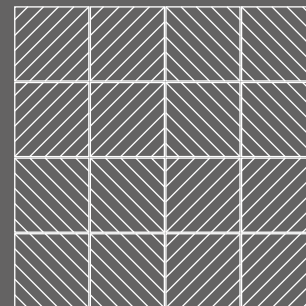
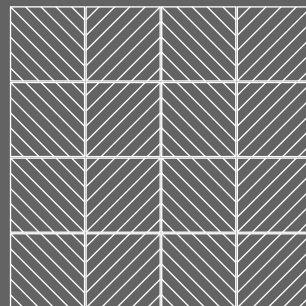
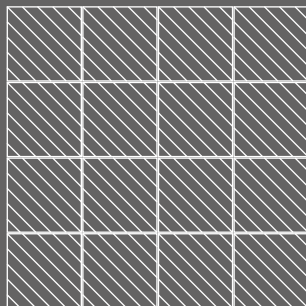

Transverse 4

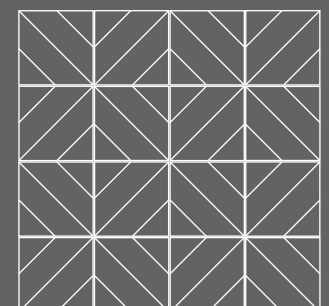
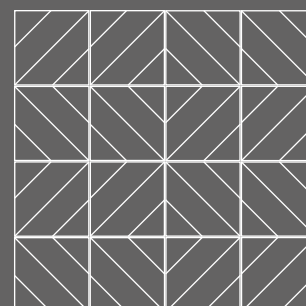
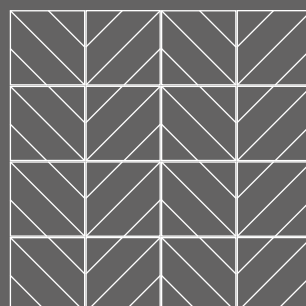
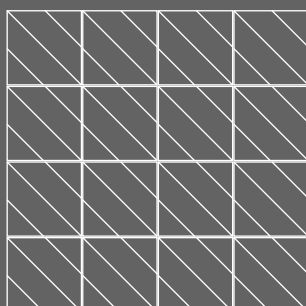

#5

London White / Golden / Titanium

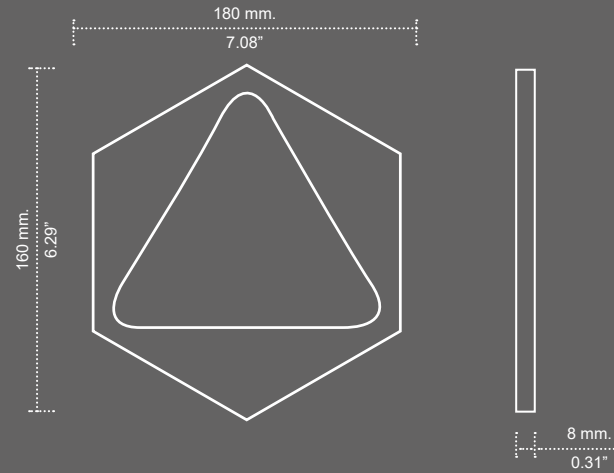

Majestic Nácar

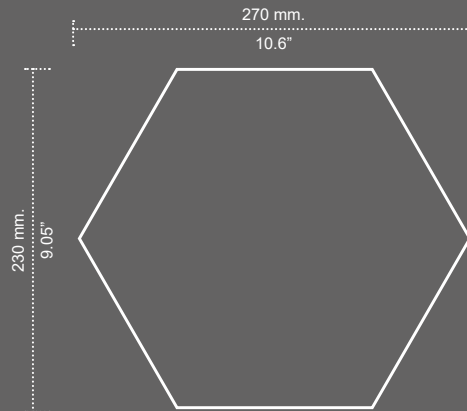

Majestic Decor Nácar / Gold / Metal

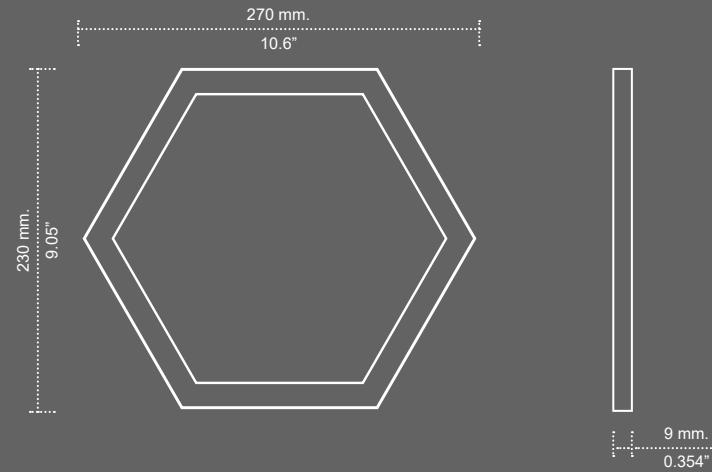

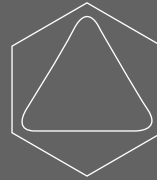

London

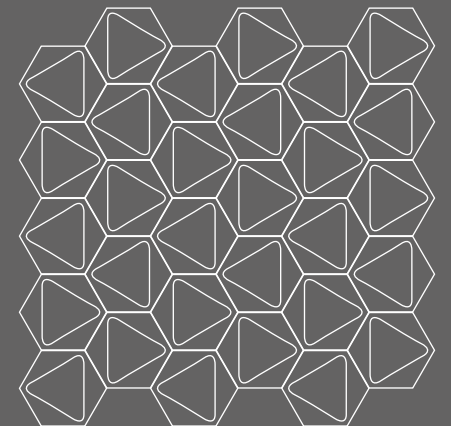
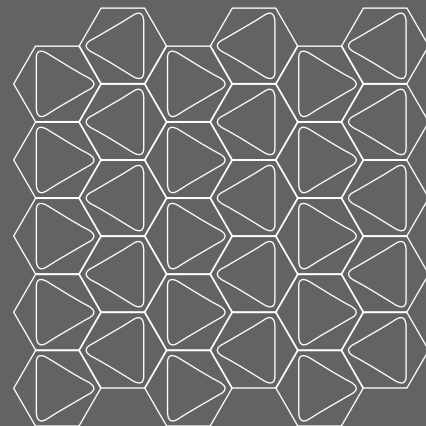
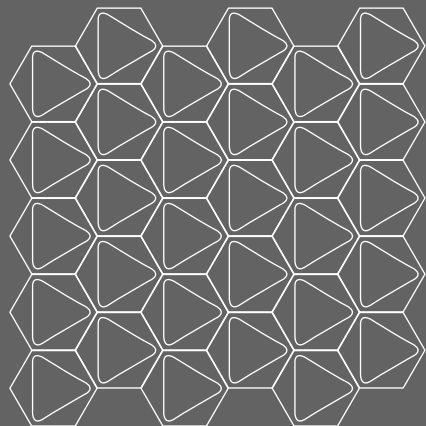
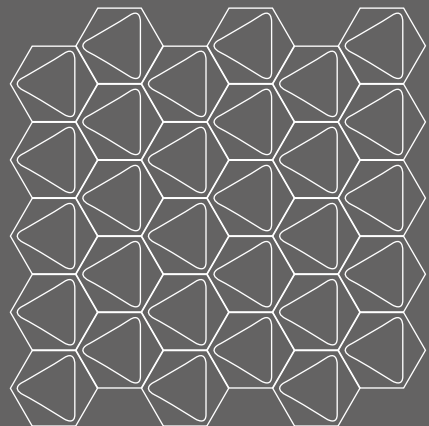
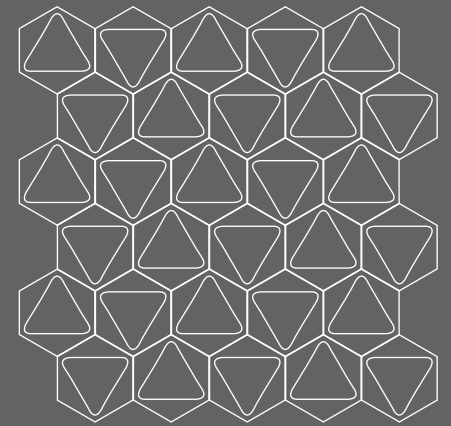
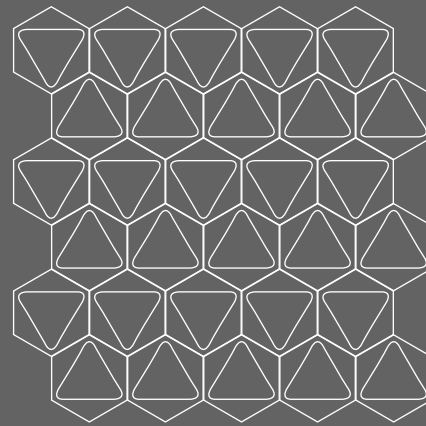
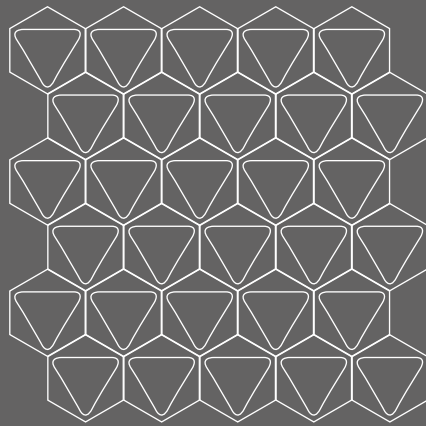
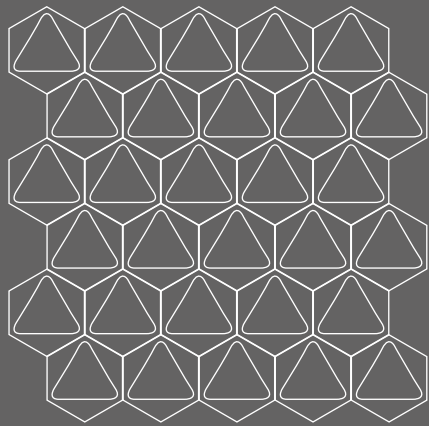

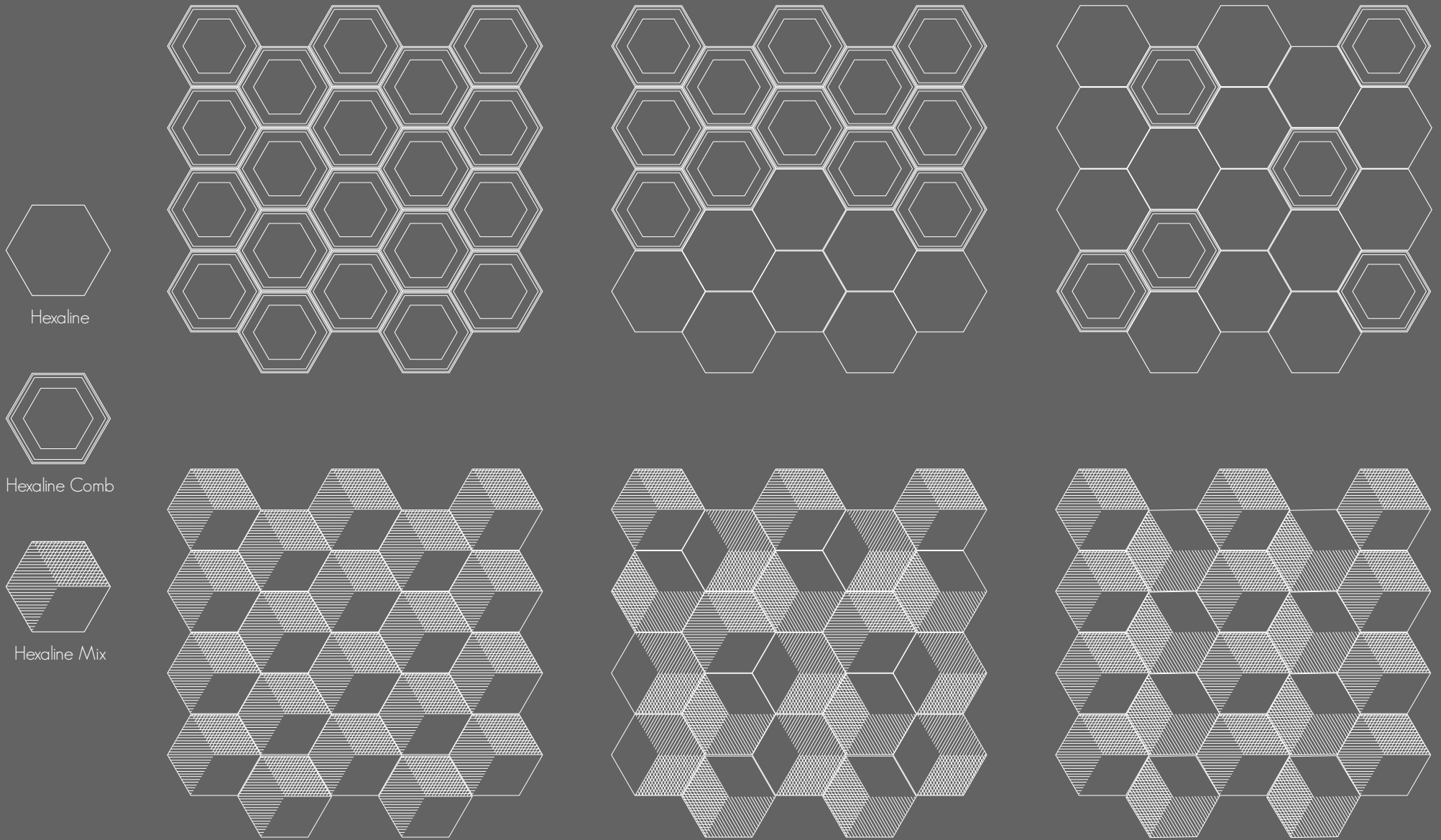

Hexaline

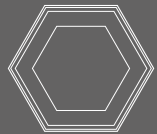

Hexaline Comb



Hexaline Mix

TABLA EMBALAJES Y USOS / PACKAGING AND USE LIST

Aria 25x25	•		•							•		•
Bivio 25x25	•		•							•		•
Hexaline Black/ White 21,5x25	•	C	•	•	•	C	•			•	C	•
Hexaline Comb / Mix 21,5x25	•	C	•							•		•
Japan 25x25	•		•							•		•
Kioto 25x25	•		•							•		•
London Golden 16x18	•		•							•		•
London Titanium 16x18	•		•							•		•
London White 16x18	•		•							•		•
Luna 25x25	•		•							•		•
Majestic Decor Chrome 23x27	•		•							•		•
Majestic Decor Gold 23x27	•		•							•		•
Majestic Decor Metal 23x27	•		•							•		•
Majestic Decor Nacar 23x27	•		•							•		•
Majestic Decor Rose Gold 23x27	•		•							•		•
Majestic Nacar 23x27	•		•							•		•
Mandorla 25x25	•		•							•		•
Multishapes 25x25	•		•							•		•
Origami 25x25	•		•							•		•
Shapes 25x25	•		•							•		•
Stripes 25x25	•		•							•		•
Transverse 1/2/3/4 14,7x14,7	•	C	•							•		•

Aria 25x25	16,00	8	9,60	21,16	60	0,50	30,00
Bivio 25x25	16,00	10	12,50	27,56	60	0,63	37,50
Hexaline 21,5x25	24,69	24	18,72	41,27	64	0,97	62,21
Japan 25x25	16,00	8	9,66	21,31	60	0,50	30,00
Kioto 25x25	16,00	8	10,24	22,58	60	0,50	30,00
London 16x18	45,25	25	8,50	18,74	60	0,55	33,15
Luna 25x25	16,00	10	11,00	24,25	60	0,63	37,50
Majestic Decor 23x27	21,60	16	13,60	29,98	48	0,74	35,56
Majestic Nacar 23x27	21,60	20	17,60	38,80	48	0,93	44,44
Mandorla 25x25	16,00	8	9,84	21,69	60	0,50	30,00
Multishapes 25x25	16,00	8	8,73	19,24	60	0,50	30,00
Origami 25x25	16,00	8	9,58	21,11	60	0,50	30,00
Shapes 25x25	16,00	16	15,04	33,16	60	1,00	60,00
Stripes 25x25	16,00	14	13,72	30,25	60	0,88	52,50
Transverse 1 14,7x14,7	46,28	42	19,74	43,52	70	0,91	63,53
Transverse 2 14,7x14,7	46,28	38	16,91	37,28	70	0,82	57,48
Transverse 3 14,7x14,7	46,28	36	15,84	34,92	70	0,78	54,45
Transverse 4 14,7x14,7	46,28	41	17,63	38,87	70	0,89	62,02

SIMBOLOGÍA /SYMBOLS

	ES	EN	FR	DE	IT	RU	AR
	Acabado de las piezas	The finishing of the piece	Finition de la pièce	Endprodukt	Rifinitura del pezzo	отделка изделий	تشطيب الأجزاء
	Porcelánico	Porcelain	Grès cérame émaillé	Feinsteinzeug	Porcellanato	Керамогранит	بورسليني
	Brillo	Gloss finish	Brillant	Glänzend	Lucido	Глянec	معان
	Mate	Matt finish	Mat	Matt	Opaco	Матовый	مطفى
	Satinado	Satin finish	Satiné	Satinient	Satinato	Сатиновый	مصقول
	Monocromática: los azulejos del mismo tono son muy uniformes, de un solo color	Monochromatic: tiles of the same tone are very uniform, of a single color	Monochromatique : Les carreaux du même ton sont très uniformes, d'une seule couleur	Einfarbig. Die Fliesen sind gleichmäßig im gleichen Ton aus einer Farbe	Monocromatico: piastrelle della stessa tonalità sono molto uniformi, di un unico colore	Монохромность: плитки одного тона очень однородны, одного цвета	أحادي اللون: يكون الزليج من نفس درجة اللون موحداً للغاية، لون واحد فقط
	Aspecto uniforme: color uniforme, las diferencias entre los azulejos de un mismo lote de producción son mínimas.	Uniform appearance: uniform color, the differences between tiles from the same production batch are minimal	Couleur uniforme, les différences entre les carreaux d'un même lot de production sont minimes	Uniforme Ansicht: Einheitliche Farbe, Farbliche Unterschiede zwischen den Fliesen der selben Charge sind minimal	Aspetto uniforme: colore uniforme, le differenze tra le piastrelle dello stesso lotto di produzione sono minime	Единый внешний вид: однородный цвет, различия между плитками из одной партии минимальны	مظهر موحد: لون موحد، تكون الاختلافات أقل بين الزليج من نفس دفعة الإنتاج
	Variación leve: diferencias visibles en el aspecto de la superficie y los motivos dentro de un mismo lote de producción	Slight variation: visible differences in surface appearance and motifs within the same production batch	Légère variation: Différences visibles d'aspect de surface et de motifs au sein d'un même lot de production	Leichte Variation: Sehbare Differenzen bei Ansicht der Oberfläche und der Motive innerhalb der selben Charge	Leggera variazione: differenze visibili nell'aspetto superficiale e nei motivi all'interno dello stesso lotto di produzione	Небольшие отклонения: видимые различия во внешнем виде поверхности и рисунках в одной производственной партии	اختلاف طفيف: اختلافات واضحة في مظهر السطح والزخارف من نفس دفعة الإنتاج.
	Variación moderada: variación considerable en el aspecto superficial, los motivos y el color entre un azulejo y otro, y dentro del propio azulejo. Es aconsejable visualizar la gama cromática antes de seleccionar el material	Moderate variation: considerable variation in surface appearance, patterns and color from one tile to another and within the tile itself. It is advisable to view the color gamut before selecting the material	Variation considérable de l'aspect de la surface, des motifs et de la couleur d'un carreau à l'autre et à l'intérieur même du carreau. Il est conseillé de visualiser la gamme de couleurs avant de sélectionner le matériau	Moderate Variation: Beträchtliche Variation bei Ansicht der Oberfläche zwischen den Motiven und der Farbe zwischen einer Fliese und der Anderen. Es ist ratsam, die Farbpalette vor der Verwendung des Materials zu visualisieren	Variazione moderata: variazione considerevole nell'aspetto della superficie, nei motivi e nel colore da una piastrella all'altra e all'interno della piastrella stessa. Si consiglia di visualizzare la gamma di colori prima di selezionare il materiale	Умеренные вариации: значительные различия во внешнем виде поверхности, узорах и цвете от одной плитки к другой и внутри самой плитки. Желательно перед выбором материала просмотреть цветовую гамму	اختلاف معتدل: اختلاف كبير في مظهر السطح والزخارف واللون من بلاطة إلى أخرى وداخل الزليج نفسه. ينصح بعرض التدرج اللوني قبل اختيار المادة.
	Variación sustancial/aleatoria: variaciones irregulares entre un azulejo y otro. Un azulejo puede ser completamente diferente de otro en el aspecto superficial y el color. Es aconsejable visualizar la gama cromática antes de seleccionar el material	Substantial / Random Variation - Irregular variations from one tile to another. One tile can be completely different from another in surface appearance and color. It is advisable to view the color gamut before selecting the material	Variation substantielle / aléatoire - Variations irrégulières d'un carreau à l'autre. Un carreau peut être complètement différent d'un autre en apparence et en couleur. Il est conseillé de visualiser la gamme de couleurs avant de sélectionner le matériau	Substanzielle/zufällige Variation: irreguläre Variation zwischen einer und der anderen Fliese. Eine Fliese kann bei Farbe und Oberflächenstruktur komplette Unterschiede aufweisen. Es ist ratsam, die Auswahl vor Verwendung zu visualisieren.	Variazione sostanziale / casuale - Variazioni irregolari da una tessera all'altra. Una piastrella può essere completamente diversa da un'altra per aspetto e colore della superficie. Si consiglia di visualizzare la gamma di colori prima di selezionare il materiale	Существенное / случайное изменение - нерегулярные изменения от одной плитки к другой. Одна плитка может полностью отличаться от другой по внешнему виду и цвету поверхности. Желательно перед выбором материала просмотреть цветовую гамму	اختلاف جوهري/عشوائي: اختلافات غير منتظمة من بلاطة إلى أخرى. يمكن أن يكون الزليج مختلفاً تماماً عن الزليج الآخر في مظهر السطح واللون. ينصح بعرض التدرج اللوني قبل اختيار المادة

En las colecciones que presenten grados de destonificación V2, V3 y V4, se recomienda tomar azulejos de varias cajas para garantizar una mayor variedad y alternancia cromática y gráfica y así conseguir un mayor efecto natural.

In collections that present degrees of detonation V2, V3 and V4, it is recommended to take tiles from several boxes to guarantee a greater variety with chromatic and graphic alternation to achieve a more natural effect.

Dans les collections montrant les degrés de détonation V2, V3 et V4, il est recommandé de prélever des carreaux de plusieurs cases pour garantir une plus grande variété et alternance chromatique et graphique et ainsi obtenir un effet naturel plus grand.







Bei den Kollektionen mit Tonalitätsdifferenzen V2, V3 und V4 wird empfohlen, Fliesen verschiedener Verpackungen miteinander zu mischen, um damit ein variantenreicheres grafisches Bild und einen natürlicheren Effekt zu erreichen.

In collezioni che mostrano gradi di detonazione V2, V3 e V4, si consiglia di prelevare piastrelle da più scatole per garantire una maggiore varietà e alternanza cromatica e grafica e ottenere così un maggiore effetto naturale

В коллекциях со степенью детонации V2, V3 и V4 рекомендуется брать плитку из нескольких коробок, чтобы гарантировать большее разнообразие, хроматическое и графическое чередование и таким образом добиться большего естественного эффекта.

يوصى بأخذ الزليج من عدة V4، و V3 و V2 في المجموعات ذات درجات ألوان تصاديق لضمان تنوع أكبر وتناوب لوني ونقشي وبالتالي تحقيق تأثير طبيعي أكبر.

SIMBOLOGÍA /SYMBOLS

	ES	EN	FR	DE	IT	RU	AR
	Acabado de las piezas	The finishing of the piece	Finition de la pièce	Endprodukt	Rifinitura del pezzo	отделка изделий	تشطيب الأجزاء
	Aplicación metálica PVD	PVD metallic application	Application métallique PVD	PVD Beschichtung	Applicazione metallica tramite PVD	Гальваника	تطبيق معدني بي في دي
	Delicado	Delicate	Délicat	Empfindlich	Delicato	Деликатный продукт	رقيق
	Variación gráfica	Graphic variation	Variation graphique	Grafische Variation	Variazione grafica	Графическая вариация	اختلاف النقش
	Textura irregular: Material que destaca por tener una superficie asimétrica	Irregular texture: Material that stands out for having an asymmetrical surface	Texture irrégulière : matériau qui se distingue par sa surface asymétrique	Ungleichmäßige Textur: Material, welches eine asymmetrische Oberfläche aufweist	Texture irregolare: materiale che si distingue per avere una superficie asimmetrica	Неровная текстура: материал, отличающийся асимметричной поверхностью	تركيب غير منظم: مادة تتميز بسطح غير متماثل
	Disponibile hasta fin de existencias	Available while stocks last	Disponibile jusqu'à épuisement des stocks	Solange Vorrat reicht	Disponibile fino ad esaurimento rimanenze	будет в наличии до окончания стока	متوفر حتى نهاية المخزون
	Apto para pared de ducha	Suitable for walls in wet area	Convient au mur de douche	Für Duschwände geeignet	Adatto per parete doccia	подходит для настенного покрытия в душе	مناسب لجدار الحمام
	Espesor	Thickness	Épaisseur	Stärke	Spessore	толщина	السماكة

Cada símbolo, meramente indicativo, se debe relacionar con la normativa específica correspondiente.

Each symbol, merely indicative, must be related to the corresponding specific regulations.

Chaque symbole, purement indicatif, doit être lié aux réglementations spécifiques correspondantes.

Alle Symbole sind unverbindlich und müssen in Zusammenhang mit den bestehenden Normen betrachtet werden.

Ogni simbolo, puramente indicativo, deve essere correlato alle corrispondenti normative specifiche.

Каждый символ, носящий чисто ориентировочный характер, имеет отношение к соответствующим конкретным правилам.

يجب أن يكون كل رمز، مجرد إرشادي، مرتبطاً باللوائح المحددة ذات الصلة

ALREDEDOR DEL MUNDO

DUNE es sinónimo de **servicio**, queremos ser aliados de nuestros clientes, repartidos en más de **80 países**, y ayudarles a que los productos DUNE lleguen a todo el mundo en el menor tiempo posible.

Para DUNE todos los pedidos son importantes, desde una pieza hasta grandes cantidades, por ello disponemos de **7 filiales** propias, repartidas por todo el mundo y una extensa red comercial y logística, capaz de gestionar cualquier pedido.

ALL AROUND THE **WORLD**

DUNE is synonymous with **service**, we partner with our customers in more than **80 countries** and help them deliver DUNE products to the whole world in the shortest possible time.

For DUNE all orders are important, from one piece to large quantities, thus we have **7 subsidiaries**, spread all over the world, and an extensive commercial and logistics network, capable of managing any order.

MEXICO
Tel./Fax: +52(55) 53004576
ventas@dune.com.mx
Sevilla 821
Col. Portales Sur
Delegación Benito Juárez
C.P. 03300

USA
Tel.: 888 608 6881
Fax: 877 374 1007
florida@duneusa.com
2302 Vinson Lane, Unit 2
Jacksonville, FL 32207

PORTUGAL
Tel.: +351 261430070
Fax: +351 261430079
gamauno@gamauno.pt
Rua da Cruz, 86
2565-031 Campelos
Torres Vedras

CHINA
Tel: +86 757 6329 7600
contact@duneceramics.cn
Room 1601, Building T5, Smart
City, No. 26 Jihua Yi Road, 528000,
Foshan
佛山市禅城区季华一路26号智慧新城T5座1601室 邮编528000

BRASIL
TEL: (47) 3349-2921
contato@dunebrasil.com.br
Avenida dos estados, nº 4770
Bairro: Estados
Casa hall offices - Sala 101
Cep: 88.339-060
Balneário camboriú- (SC)

ARGENTINA
Tel.: +54 114 6362568
Fax: +54 114 6740135
administracion@duneargentina.com.ar
José Bonifacio, 3844
C1407 HEL Buenos Aires

ESPAÑA - Oficinas Centrales/Headquarters
Tel.: +(34) 964 657 400
Fax: +(34) 964 657 401
dune@dune.es
Partida Rachina s/n, 12130
San Juan de Moró (Castellón)

© Copyright DUNE CERAMICA S.L. Reservados todos los derechos.
Catálogo Shapes - Junio 2021

Dune Cerámica se reserva el derecho de modificar las características de sus productos sin preaviso de ningún tipo.
Los acabados se dan a título indicativo, quedando bajo reserva los ajustes de los colores consecuencia de las técnicas de impresión.
Por ello, las fotografías de los productos expuestos no son contractuales.
La interpretación de las ilustraciones estará en función del criterio del creador.
Los textos que aparecen en el catálogo quedan bajo reserva de posible error por composición o inserción de página.
Este catálogo es meramente informativo.

© Copyright DUNE CERAMICA S.L. All rights reserved.
Shapes Catalogue - June 2021

Dune Cerámica reserves the right to change the characteristics of its products without prior notice.
Information about the finishes of the goods is only provided as a guide.
As a result of the printing techniques, there might be differences between the colours printed in this catalogue and those of the real products.
Colours shown in this catalogue are not contractual.
The images are for illustration purpose only and are subject to the designer's interpretation.
This catalogue is for information purposes only.

SHAPES

by

DUNE



ESPAÑA - Oficinas Centrales/Headquarters
Partida Rachina s/n, 12130 - San Juan de Moró(Castellón)
Tel.:+(34) 964 657 400 - Fax:+(34) 964 657 401
dune@dune.es - www.duneceramics.com

